

KENTUCKY TRANSPORTATION CABINET

AET REFERENCE DRAWINGS

Typical All-Electronic Tolling (AET) Toll Zone Guidelines

- C-1 Typical Mainline AET Toll Zone Plan View
- C-2 Typical 2 Lane Ramp AET Toll Zone Plan View
- C-3 Typical 1 Lane Ramp AET Toll Zone Plan View
- C-4 AET Toll Zone Access & Signing
- C-5 Typical Mainline/Ramp Loop and Joint Locations Detail for Pavement
- A-1 Typical AET Toll Zone Vault Plan
- A-2 Typical AET Toll Zone Vault Elevations
- A-3 Upstream Mainline AET Toll Zone Gantry Elevations, Single Direction - Front View (6 Lane)
- A-4 Upstream Mainline AET Toll Zone Gantry Elevations, Single Direction - Rear View (6 Lane)
- A-5 Downstream Mainline AET Toll Zone Gantry Elevations, Single Direction - Front View (6 Lane)
- A-6 Upstream Mainline AET Toll Zone Gantry Elevations, Single Direction - Front View (5 Lane)
- A-7 Upstream Mainline AET Toll Zone Gantry Elevations, Single Direction - Rear View (5 Lane)
- A-8 Downstream Mainline AET Toll Zone Gantry Elevations, Single Direction - Front View (5 Lane)
- A-9 Upstream Mainline AET Toll Zone Gantry Elevations, Bi-Directional - Front View (6 Lane)
- A-10 Upstream Mainline AET Toll Zone Gantry Elevations, Bi-Directional - Rear View (6 Lane)
- A-11 Downstream Mainline AET Toll Zone Gantry Elevations, Bi-Directional - Front View (6 Lane)
- A-12 Typical AET Toll Gantry Side Elevation - Single Direction
- A-13 Typical AET Toll Gantry Side Elevation - Bi-Directional
- E-1 Typical Mainline AET Toll Zone Conduit Detail
- E-2 Typical Ramp AET Toll Zone Conduit Detail
- E-3 AET Toll Zone Cabinets with Concrete Pads
- E-4 Toll Zone Vault Electrical Plan
- E-5 Toll Zone Vault Conduit Plan

Abbreviations

- AET - All-Electronic Tolling
- AVC - Automatic Vehicle Classification
- AVI - Automatic Vehicle Identification
- C - Conduit
- C/L - Centerline
- DMS - Dynamic Message Sign
- EOP - Edge of Pavement
- E.Q. - Equal Distance
- FON - Fiber Optic Network
- ITS - Intelligent Transportation Systems
- LPS - Lightning Protection System
- NEC - National Electrical Code
- NFPA - National Fire Protection Association
- R/W - Right-of-Way
- SOW - Scope of Work
- SPD - Surge Protection Device
- TYP - Typical
- UL - Underwriters Laboratories
- UPS - Uninterruptable Power Supply



All design and installation shall conform to the latest published edition/version of the State Standard Specifications, Roadway Drawings, and, as applicable, the NFPA 70 (NEC) and UL standards.

REVISION DATE - 4/10/2013

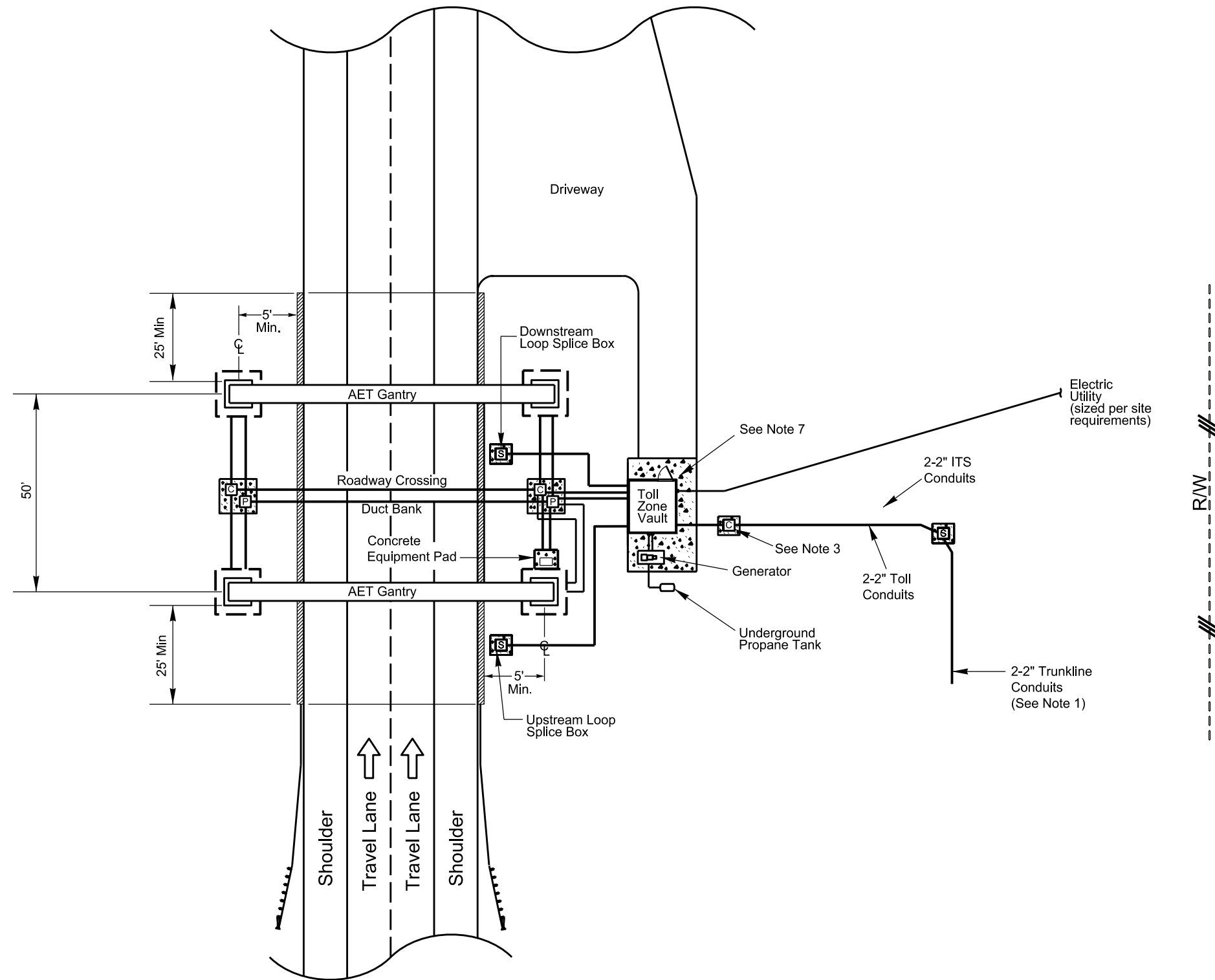

Notes:

1. The FON trunkline as shown is approximate.
2. Lane and shoulder configuration may vary.
3. For all conduit runs entering Toll Zone Vault, place conduit boxes as needed to ensure last box before entering Toll Zone Vault is below level of sidewalk concrete slab.
4. Locations and length of steel beam guardrail and location of end terminals shall be determined during design in accordance with AASHTO roadside safety design guidelines and State standards.
5. Barrier wall or guard rail shall protect toll equipment and maintenance areas at each tolling zone.
6. Provide concrete aprons for all junction boxes as per the AET Scope of Work.
7. Toll Zone Vaults may be combined with the nearest Mainline Toll Vault if it is in close proximity. Additional roadside cabinets may be anticipated if Toll Vaults are combined.

Legend

- [C] - Communications Junction Box
- [P] - Power Junction Box
- [S] - Loop Splice Box
- [Box] - Box with 18" concrete apron; 1" above grade
- [Guardrail] - Guardrail
- [Barrier Wall] - Cast-in-Place Concrete Barrier Wall
- [Foundation] - Structure Foundation

ATKINS 1616 EAST MILLBROOK ROAD, SUITE 310 RALEIGH, NORTH CAROLINA 27609 (919) 876-6888		
KENTUCKY TRANSPORTATION CABINET AET REFERENCE DRAWINGS Typical 2 Lane Ramp AET Toll Zone Plan View		
SCALE: N.T.S.	KENTUCKY TRANSPORTATION CABINET	SHEET NO. C-2
Ver 1.1 3/22/2013		
Ver 1.2 4/12/2013		

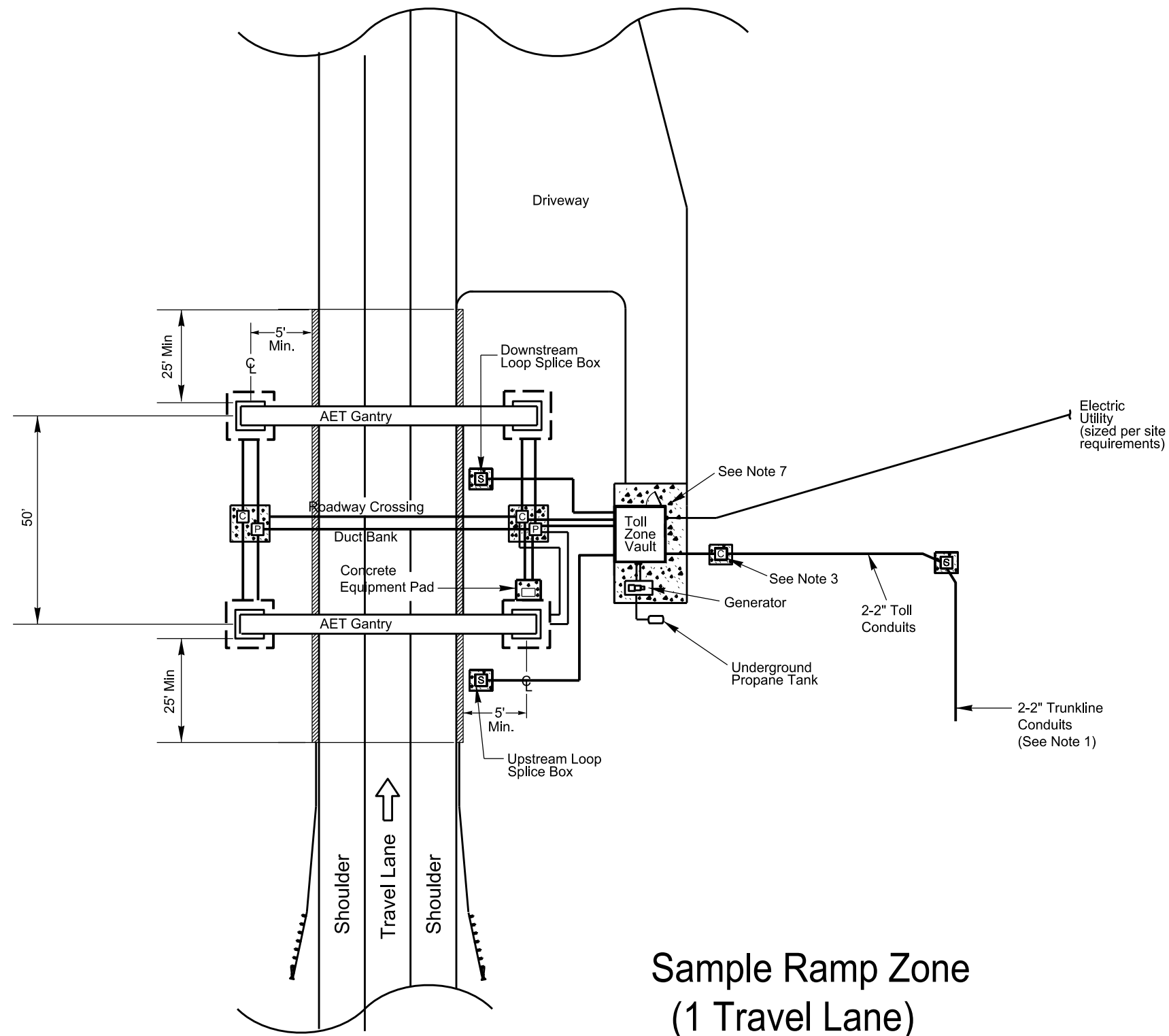

Notes:

1. The FON trunkline as shown is approximate.
2. Lane and shoulder configuration may vary.
3. For all conduit runs entering Toll Zone Vault, place conduit boxes as needed to ensure last box before entering Toll Zone Vault is below level of sidewalk concrete slab.
4. Locations and length of steel beam guardrail and location of end terminals shall be determined during design in accordance with AASHTO roadside safety design guidelines and State standards.
5. Barrier wall or guard rail shall protect toll equipment and maintenance areas at each tolling zone.
6. Provide concrete aprons for all junction boxes as per the AET Scope of Work.
7. Toll Zone Vaults may be combined with the nearest Mainline Toll Vault if it is in close proximity. Additional roadside cabinets may be anticipated if Toll Vaults are combined.

R/W

Legend

- [C] - Communications Junction Box
- [P] - Power Junction Box
- [S] - Loop Splice Box
- [Box] - Box with 18" concrete apron; 1" above grade
- [Guardrail] - Guardrail
- [Barrier Wall] - Cast-in-Place Concrete Barrier Wall
- [Foundation] - Structure Foundation

**Sample Ramp Zone
(1 Travel Lane)**

ATKINS 1616 EAST MILLBROOK ROAD, SUITE 310 RALEIGH, NORTH CAROLINA 27609 1919) 876-6888		
KENTUCKY TRANSPORTATION CABINET AET REFERENCE DRAWINGS		
Typical 1 Lane Ramp AET Toll Zone Plan View		
SCALE: N.T.S.	KENTUCKY TRANSPORTATION CABINET	SHEET NO. C-3

Sample Pull-off Design



Signing Notes:

1. TSI shall add required signing to AET Toll Zones with and without buildings. Coordinate signing with the Design Build Contractor and Developer. Sign locations are shown as sample for bidding.
2. Signing applies to both mainline and ramp AET Toll Zones.
3. Sign spacing shall be in accordance with State and MUTCD standards.
4. Sign sizes shall be in accordance with MUTCD Table 2B-1.
5. U-channel support design shall be in accordance with State standards.

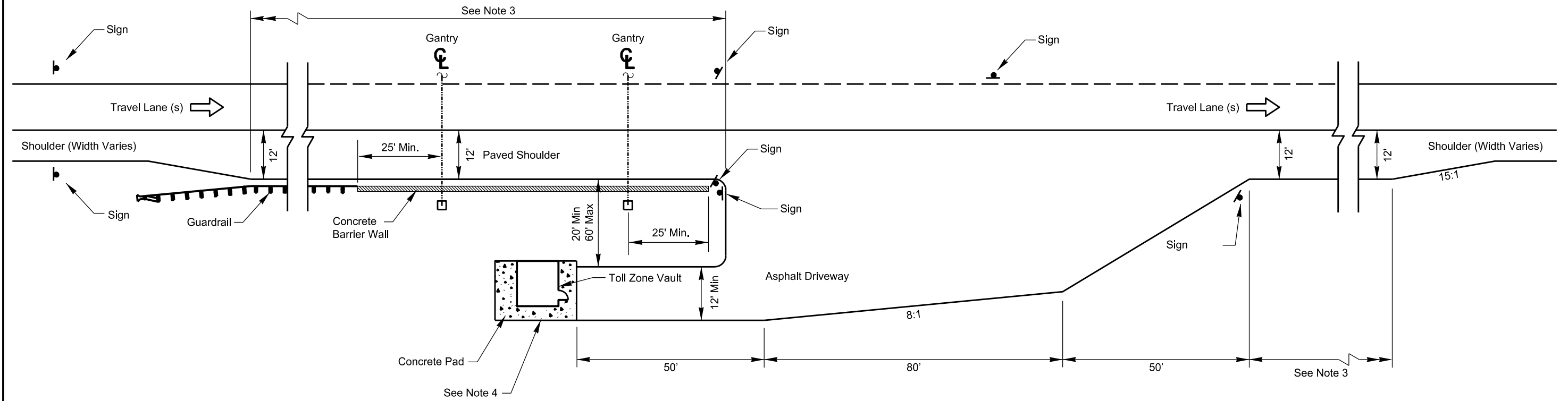

Sample Access and Signing Detail for AET Facility

Not to Scale

Notes:

1. AET Toll Zone Vault and concrete pad may vary in size.
2. Locations and length of steel beam guardrail and location of end terminals shall be determined during design in accordance with AASHTO roadside safety design guidelines and State standards.
3. Acceleration and deceleration lengths shall be determined based on the design criteria included in the Roadway Scope of Work.
4. Center Toll Zone Vault between gantries.
5. Provide driveway whether vault is present or not.

ATKINS		1616 EAST MILLBROOK ROAD, SUITE 310 RALEIGH, NORTH CAROLINA 27609 (919) 876-6888	
KENTUCKY TRANSPORTATION CABINET AET REFERENCE DRAWINGS AET Toll Zone Access & Signing			
SCALE:	N.T.S.	KENTUCKY TRANSPORTATION CABINET	SHEET NO.
			C-4

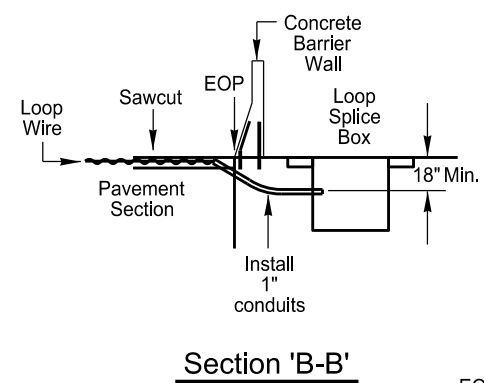
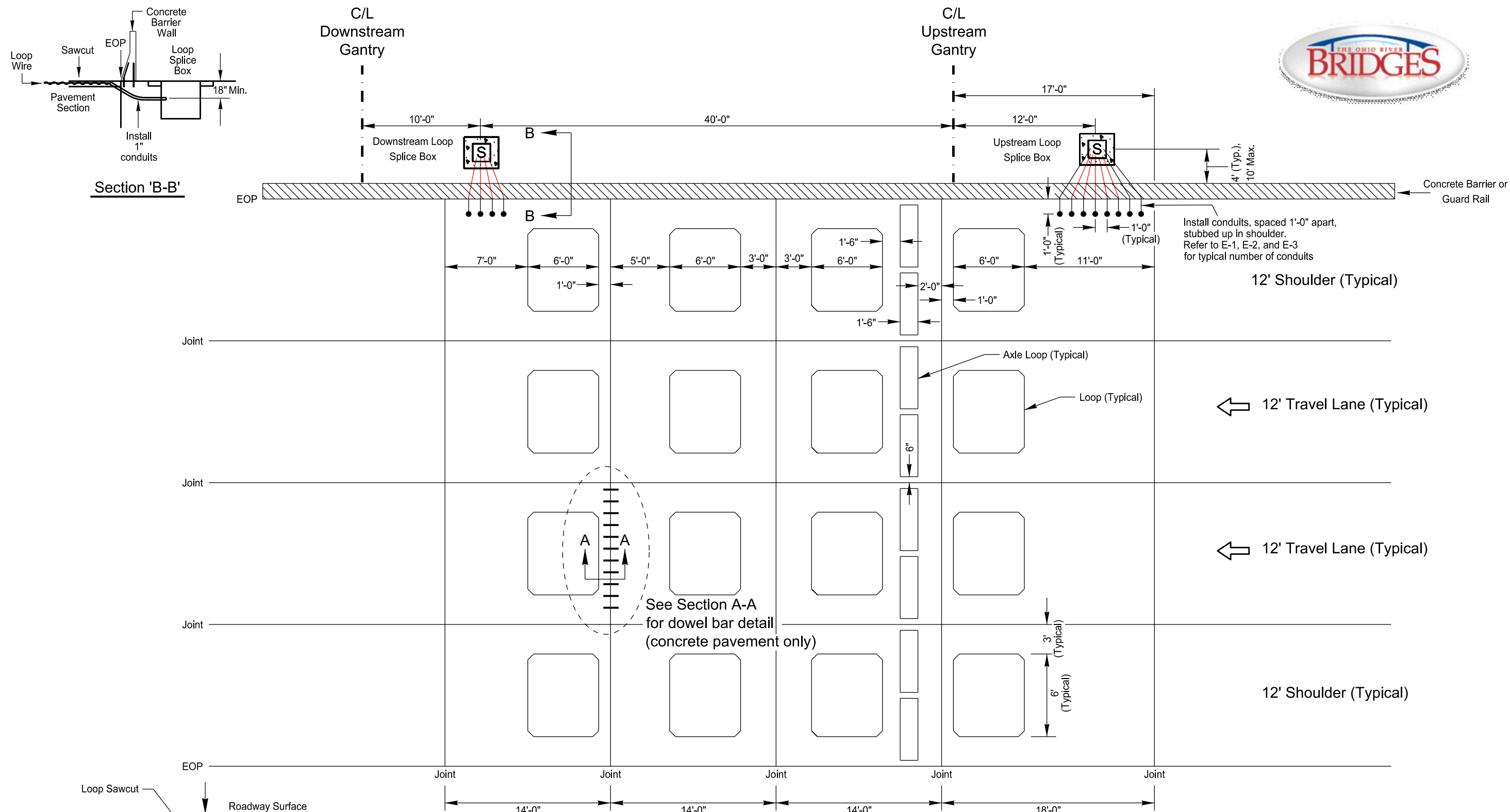

Section 'B-B'

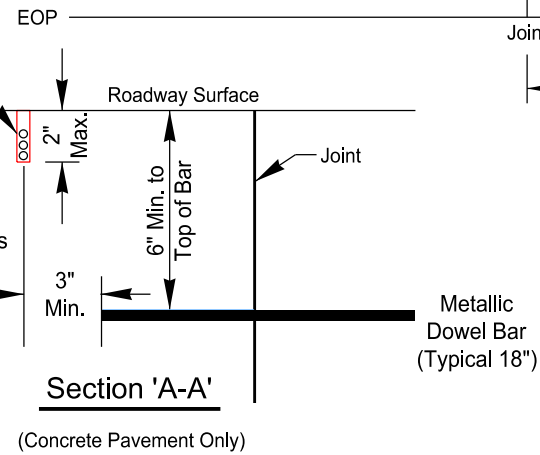

Section 'A-A'
(Concrete Pavement Only)

See Section A-A
for dowel bar detail
(concrete pavement only)

- Notes:**
1. All loops are by the Toll System Integrator.
 2. Loop layout shown is typical for 2 travel lane mainline section. Toll System Integrator is responsible for actual loop dimensions for each AET site and coordination with the Design Build Contractor and the Developer.
 3. Note: This layout is for toll zones with concrete only.

		1616 EAST MILLBROOK ROAD, SUITE 310 RALEIGH, NORTH CAROLINA 27689 (919) 876-6888 NCBEES *F-0326
KENTUCKY TRANSPORTATION CABINET AET REFERENCE DRAWINGS Typical Mainline/Ramp Loop and Joint Locations Detail for Pavement		
SCALE:	N.T.S.	KENTUCKY TRANSPORTATION CABINET
Ver 1.1	3/22/2013	
Ver 1.2	4/12/2013	
		SHEET NO.
		C-5

GENERAL NOTES:

1. See Scope of Work for additional details and requirements.
2. Provide prefabricated, pre-cast or built-in-place vault with R-24 insulation, per State building codes.
3. Provide 3/4" chamfered edge on maintenance pad.
4. Field-adjust exterior cabinets/boxes as needed for local conditions, wire size, etc.

VAULT PLAN - ELECTRICAL:

1. Provide SPDs on all distribution panels.
2. Locate conduit stub-ups a maximum of 12" from interior wall surface.
3. Provide integral safety disconnect on HVAC unit.

LIGHTING SYSTEM:

1. Provide lighting system with battery backup for power loss capable of maintaining one interior light fixture for 30 minutes minimum.

SECURITY SYSTEM:

1. Provide conduit and electrical boxes to support the electronic door security system.

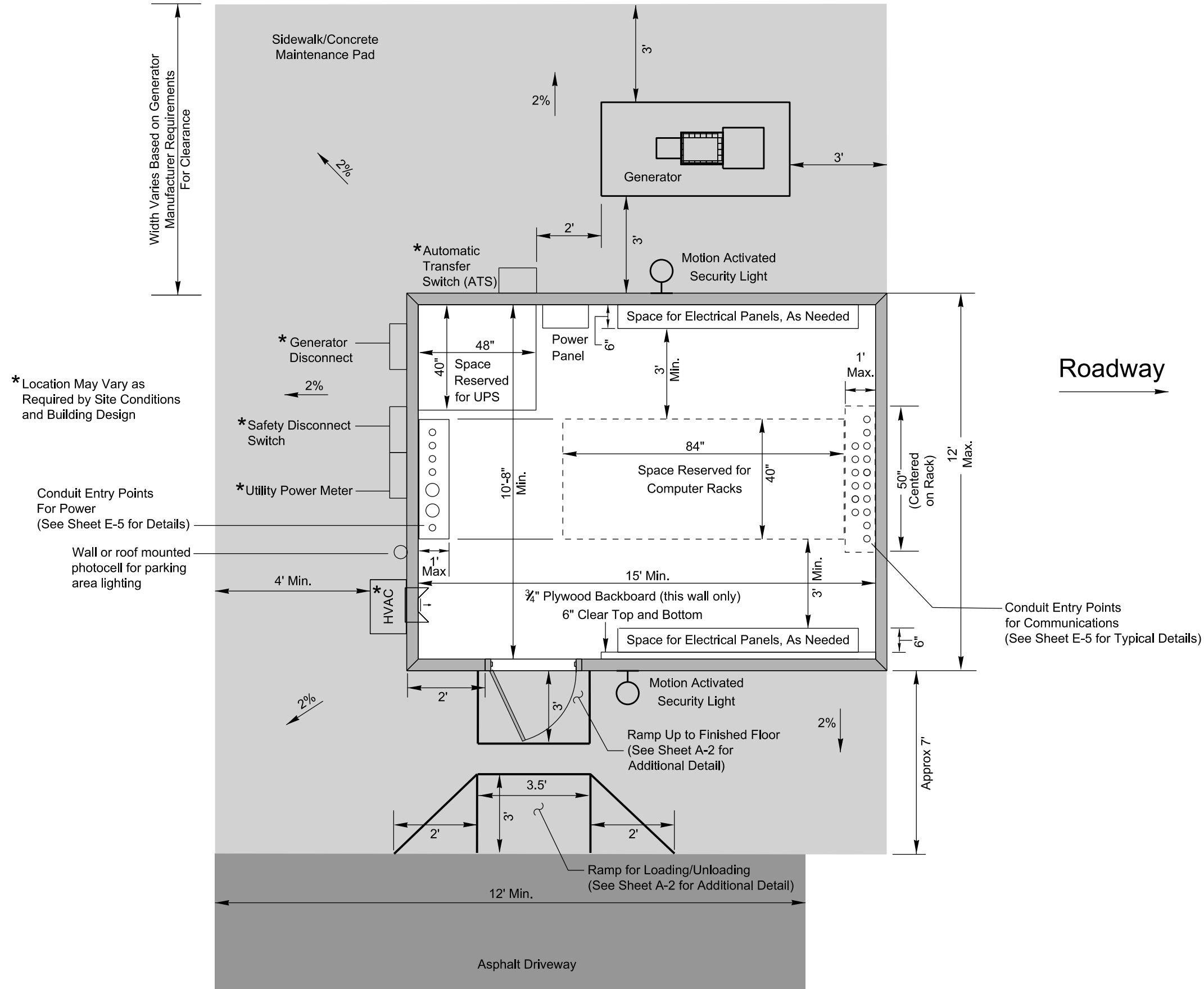

ATKINS 1616 EAST MILLBROOK ROAD, SUITE 310 RALEIGH, NORTH CAROLINA 27609 (919) 876-6888		
KENTUCKY TRANSPORTATION CABINET AET REFERENCE DRAWINGS AET Toll Zone Vault Plan		
SCALE: N.T.S.	KENTUCKY TRANSPORTATION CABINET	SHEET NO.
Ver 1.1 3/22/2013		A-1
Ver 1.2 4/12/2013		

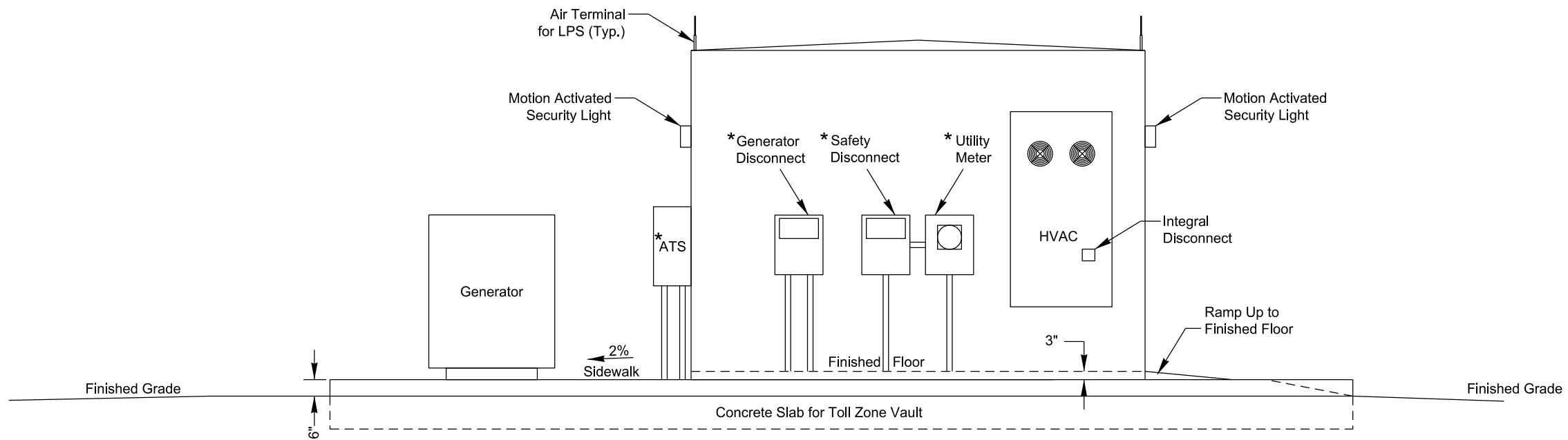

* Location May Vary as Required by Site Conditions

Side Elevation
Not to Scale

Note: Precast Building/Shelter shall be built in accordance with the RFP details. Pre-wiring and testing is recommended.

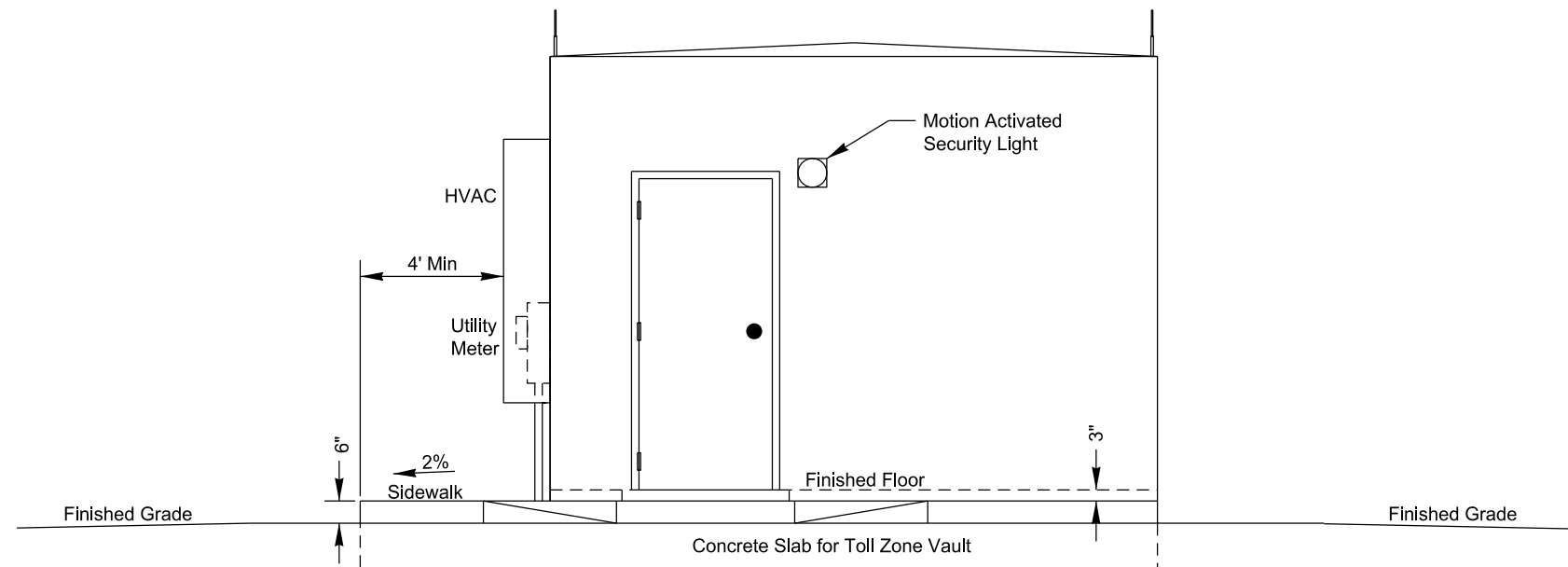

Front Elevation
Not to Scale

1616 EAST MILLBROOK ROAD, SUITE 310 RALEIGH, NORTH CAROLINA 27609 (919) 876-6888		
KENTUCKY TRANSPORTATION CABINET AET REFERENCE DRAWINGS AET Toll Zone Vault Elevations		
SCALE: N.T.S.	KENTUCKY TRANSPORTATION CABINET	SHEET NO.
Ver 1.1 3/22/2013		A-2
Ver 1.2 4/12/2013		

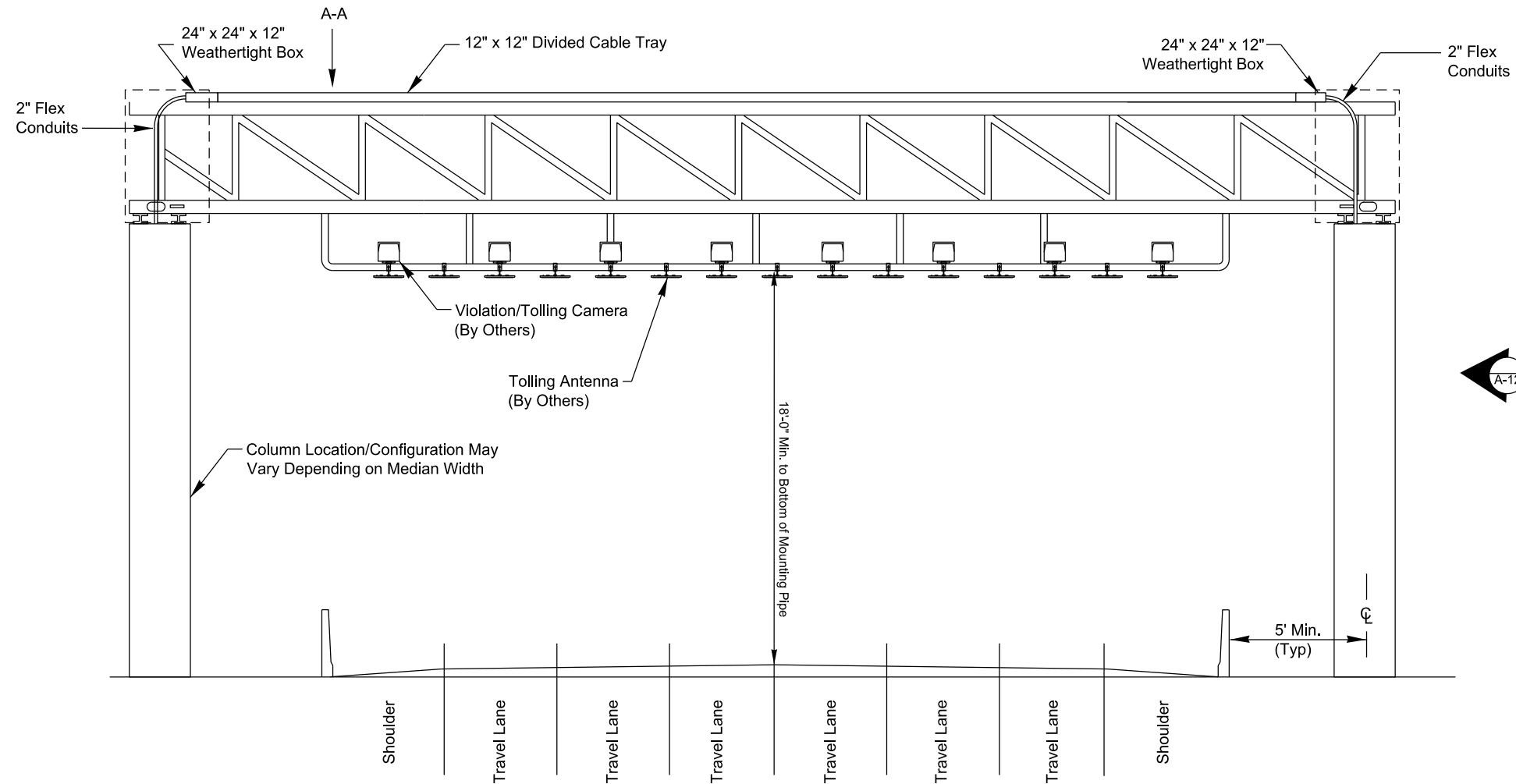

Upstream (First) Mainline Gantry Front (Approaching) Elevation Single Direction
 Not to Scale

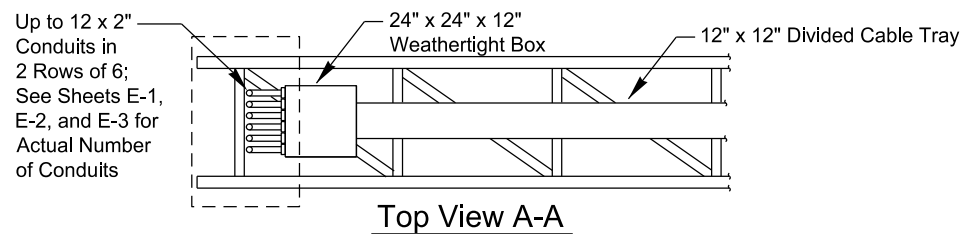

Notes:

1. Location of vertical supports to be coordinated by Toll System Integrator with Design Build Team or Developer.
2. Mounting pipes are horizontal.
3. Consider service walkways on Gantry to minimize closures for maintenance

ATKINS		1616 EAST MILLBROOK ROAD, SUITE 310 RALEIGH, NORTH CAROLINA 27609 (919) 876-6888
KENTUCKY TRANSPORTATION CABINET AET REFERENCE DRAWINGS Upstream Mainline AET Toll Zone Gantry Elevation Single Direction Front View (6 lane)		
SCALE:	N.T.S.	KENTUCKY TRANSPORTATION CABINET
Ver 1.1	3/22/2013	
Ver 1.2	4/12/2013	
		A-3

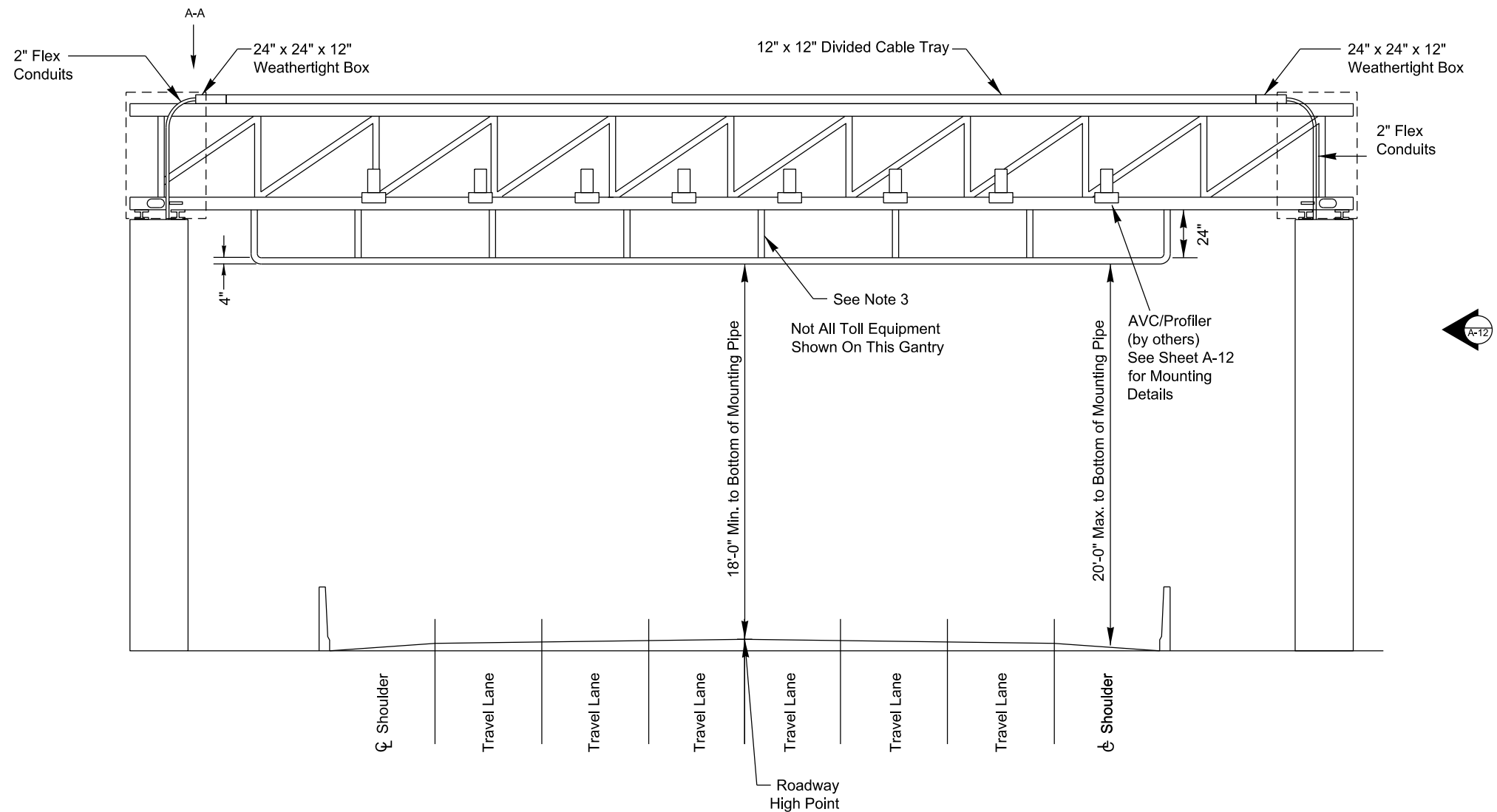

Upstream (First) Mainline Gantry Rear Elevation View, Single Direction
(Cameras and Antennas Omitted for Clarity)

Not to Scale

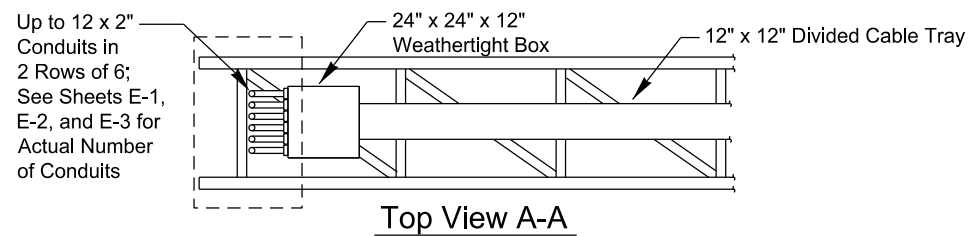

Top View A-A

Notes:

1. Location of vertical supports to be coordinated by Toll System Integrator with Design Build Team and Developer.
2. Mounting pipes are horizontal.
3. Consider service walkways on gantry to minimize closures for maintenance

		1616 EAST MILLBROOK ROAD, SUITE 310 RALEIGH, NORTH CAROLINA 27609 (919) 876-6888	
		KENTUCKY TRANSPORTATION CABINET AET REFERENCE DRAWINGS Upstream Mainline AET Toll Zone Gantry Elevation Single Direction Rear View (6 lane)	
SCALE:	N.T.S.	KENTUCKY TRANSPORTATION CABINET	SHEET NO.
Ver 1.1	3/22/2013		A-4
Ver 1.2	4/12/2013		

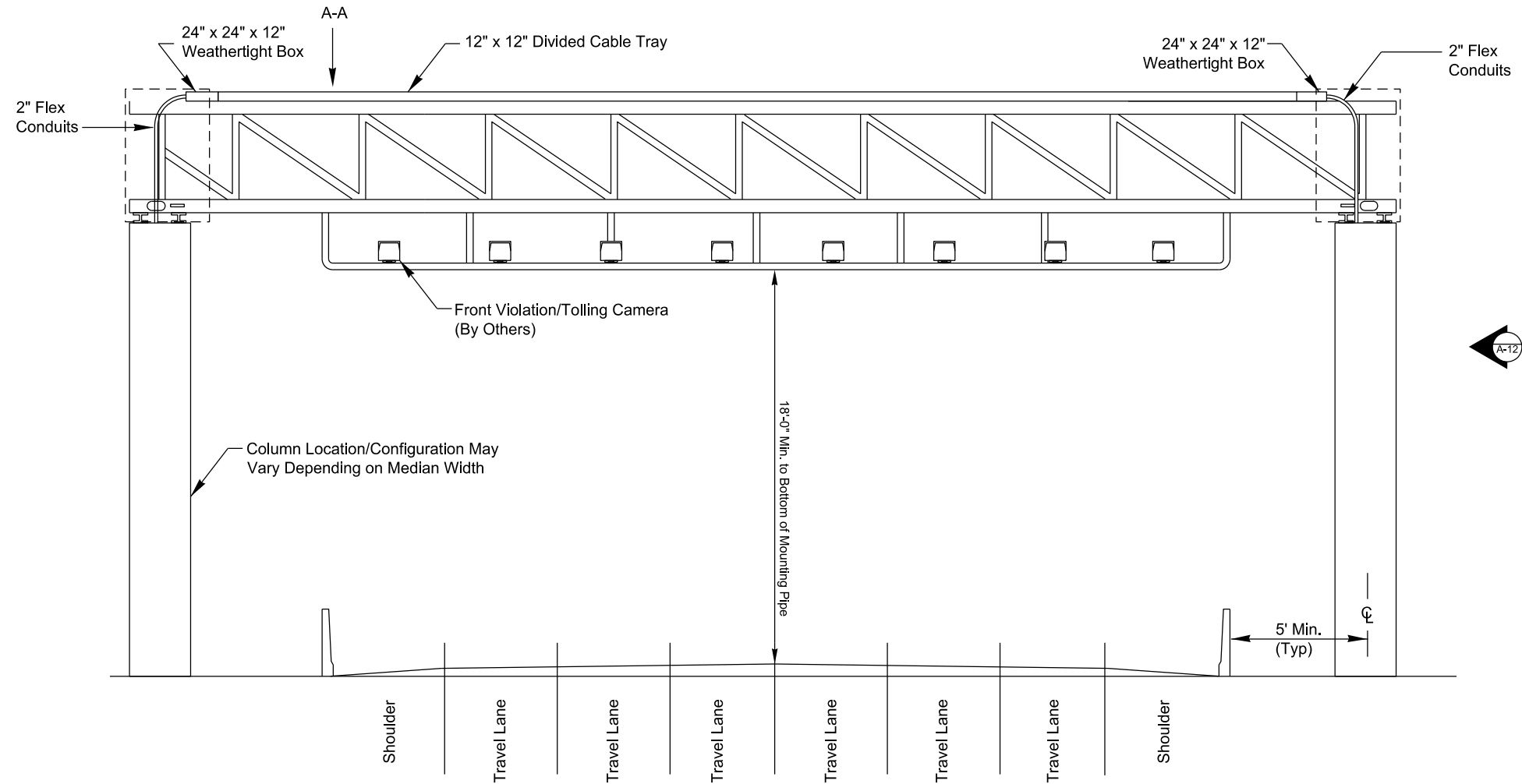

Downstream (Trailing) Mainline Gantry Front Elevation Single Direction
Not to Scale

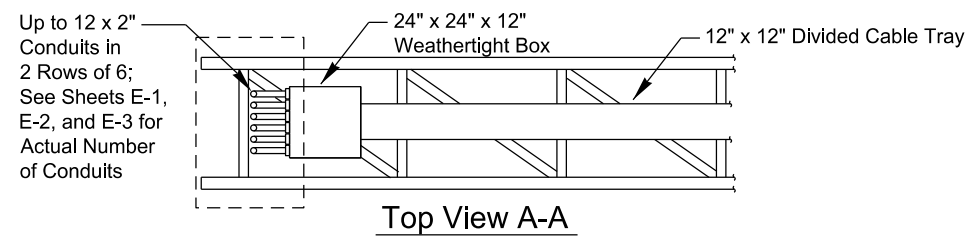

Notes:

1. Location of vertical supports to be coordinated by Toll System Integrator with Design Build Team and Developer.
2. Mounting pipes are horizontal.
3. Consider service walkways on gantry to minimize closures for maintenance

		1616 EAST MILLBROOK ROAD, SUITE 310 RALEIGH, NORTH CAROLINA 27609 (919) 876-6888	
		KENTUCKY TRANSPORTATION CABINET AET REFERENCE DRAWINGS Downstream Mainline AET Toll Zone Gantry Elevation Single Direction - Front View (6 Lane)	
SCALE:	N.T.S.	KENTUCKY TRANSPORTATION CABINET	SHEET NO.
Ver 1.1	3/22/2013		A-5
Ver 1.2	3/12/2013		

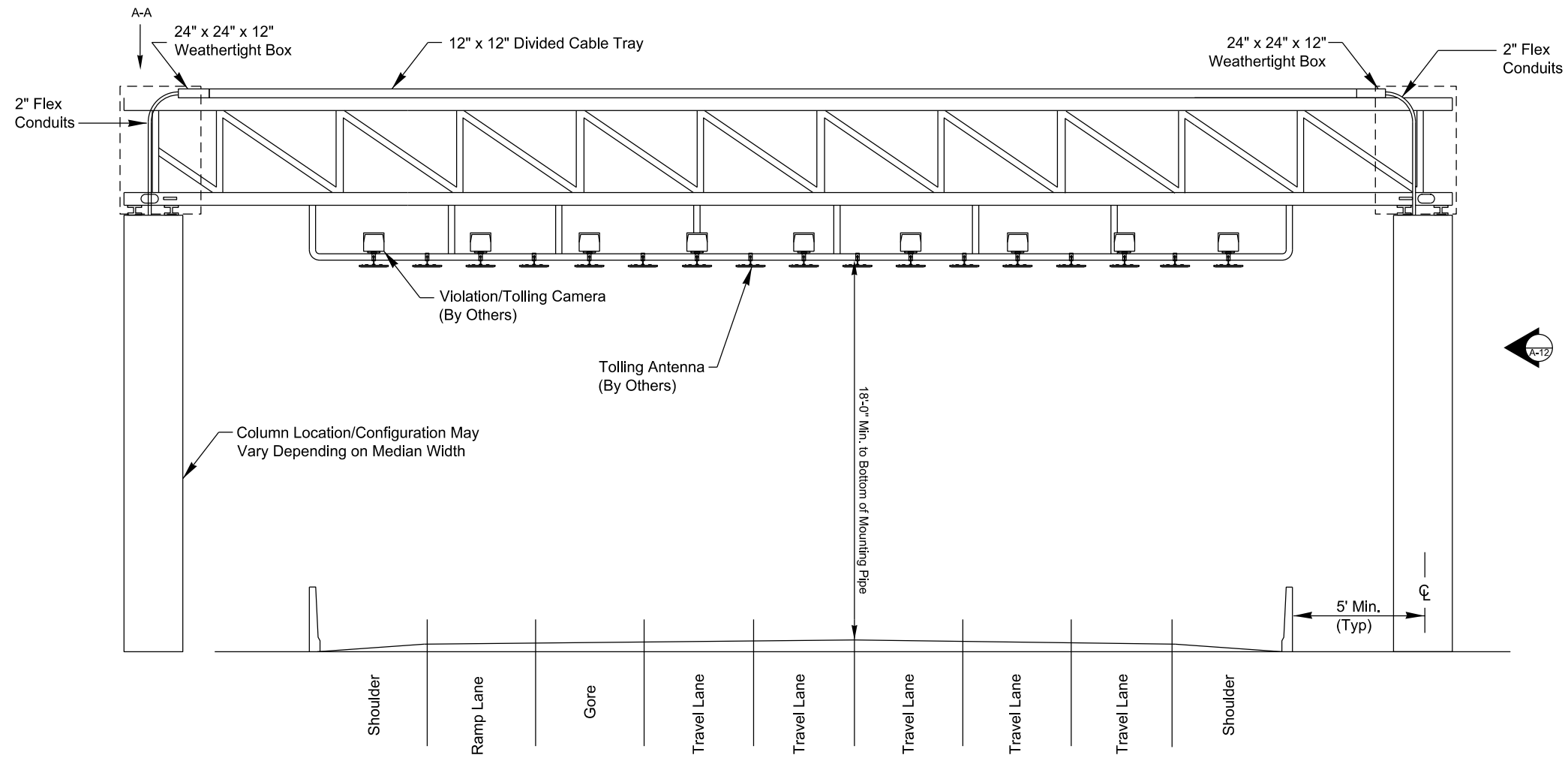

Upstream (First) Mainline Gantry Front Elevation Single Direction
Not to Scale

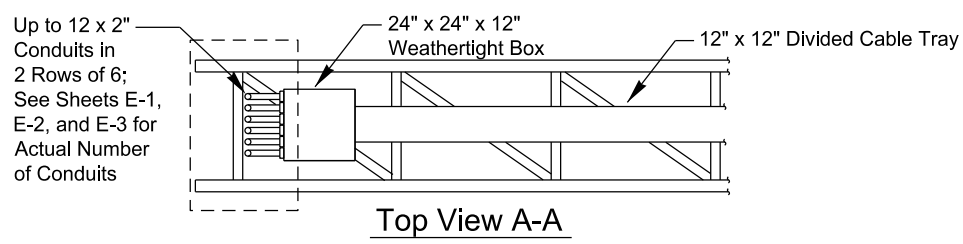

- Notes:**
1. Location of vertical supports to be coordinated by Toll System Integrator with Design Build Team and Developer.
 2. Mounting pipes are horizontal.
 3. Consider service walkways on gantry to minimize closures for maintenance

		1616 EAST MILLBROOK ROAD, SUITE 310 RALEIGH, NORTH CAROLINA 27609 (919) 876-6888
KENTUCKY TRANSPORTATION CABINET AET REFERENCE DRAWINGS Upstream Mainline AET Toll Zone Gantry Elevation Single Direction - Front View (5 Lane)		
SCALE:	N.T.S.	KENTUCKY TRANSPORTATION CABINET
Ver 1.1	3/22/2013	
Ver 1.2	4/12/2013	
		SHEET NO. A-6

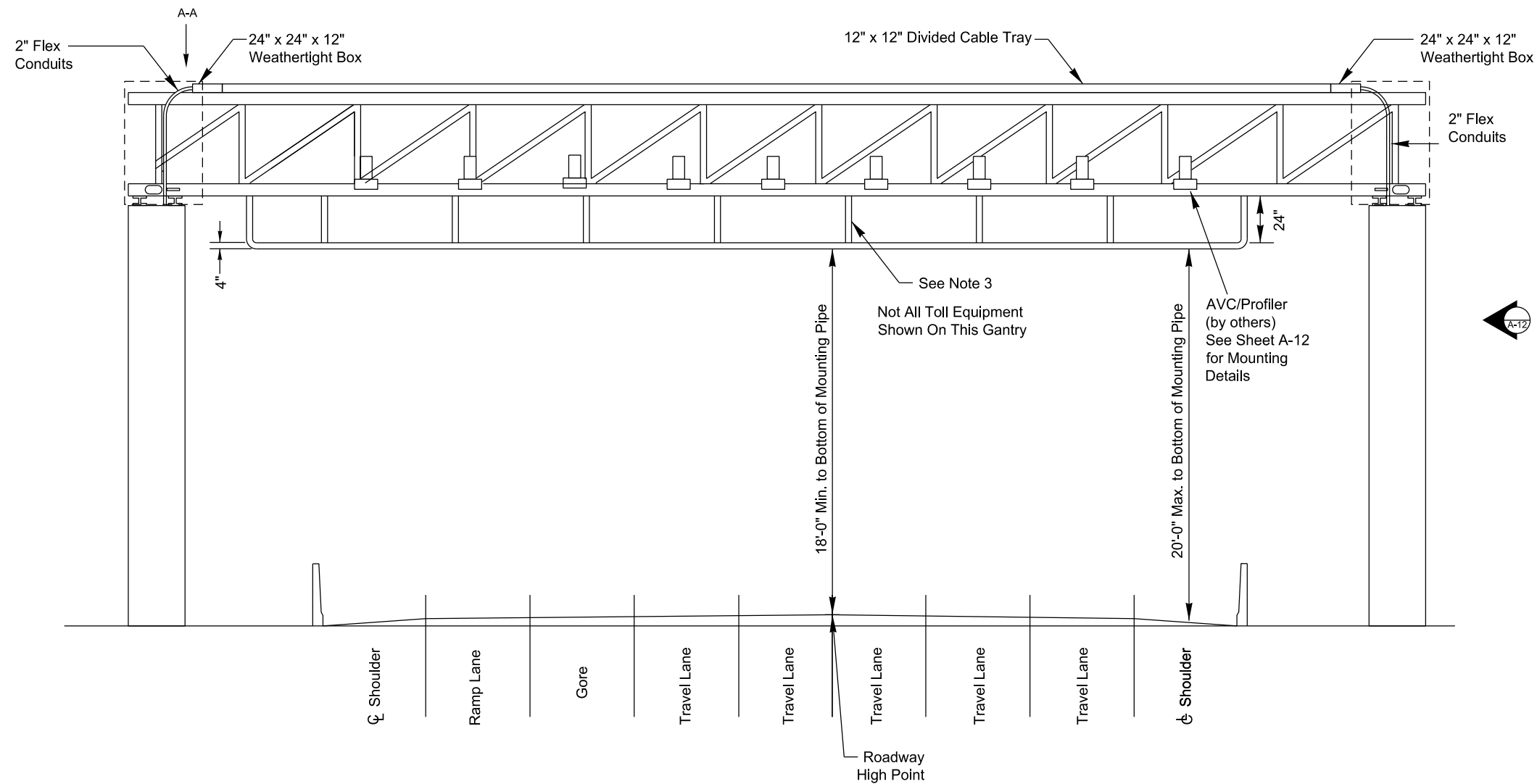

Upstream (First) Mainline Gantry Rear Elevation Single Direction
(Cameras and Antennas Omitted for Clarity)

Not to Scale

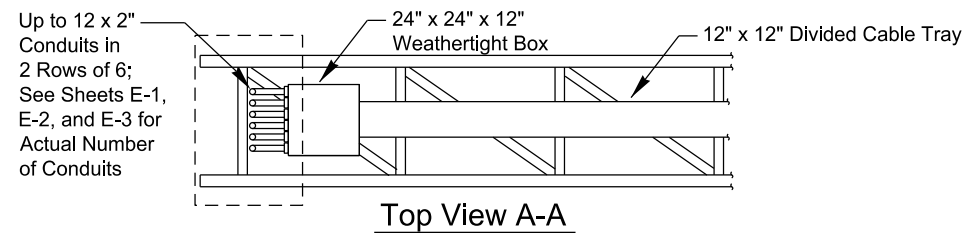

Notes:

1. Location of vertical supports to be coordinated by Toll System Integrator with Design Build Team and Developer.
2. Mounting pipes are horizontal.
3. Consider service walkways on gantry to minimize closures for maintenance.

<p>ATKINS 1616 EAST MILLBROOK ROAD, SUITE 310 RALEIGH, NORTH CAROLINA 27609 (919) 876-6888</p>		<p>KENTUCKY TRANSPORTATION CABINET</p>	SHEET NO.
			A-7
SCALE:	N.T.S.		
Ver 1.1	3/22/2013		
Ver 1.2	4/12/2013		

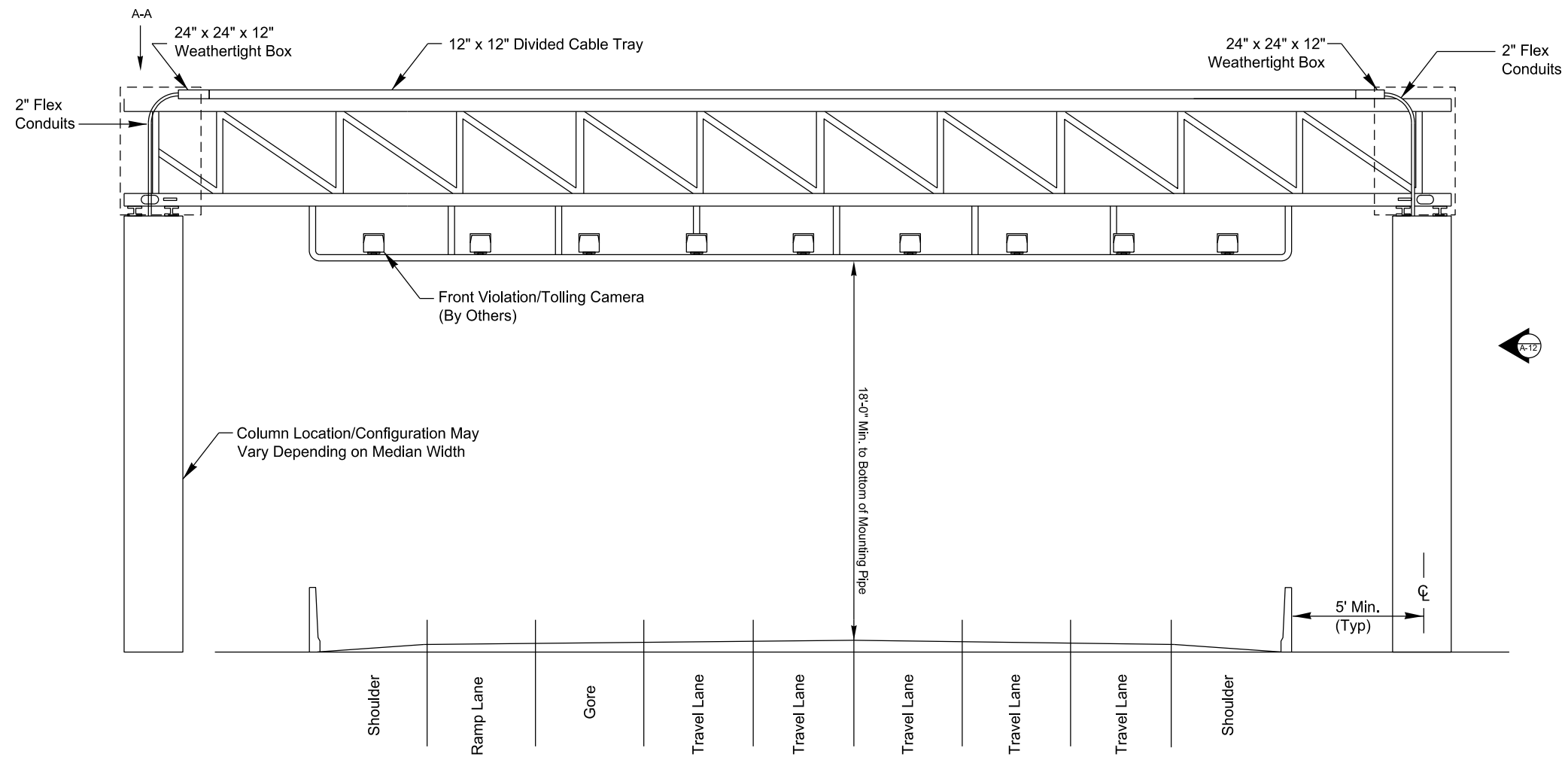

Downstream (Trailing) Mainline Gantry Front Elevation Single Direction
Not to Scale

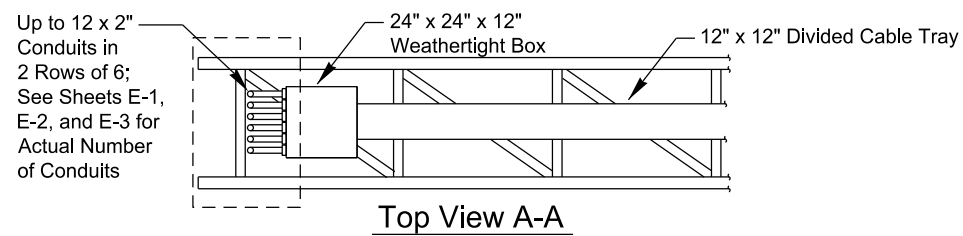

Notes:

1. Location of vertical supports to be coordinated by Toll System Integrator with Design Build Team and Developer.
2. Mounting pipes are horizontal.
3. Consider service walkways on gantry to minimize closures for maintenance.

ATKINS 1616 EAST MILLBROOK ROAD, SUITE 310 RALEIGH, NORTH CAROLINA 27609 (919) 876-6888		
KENTUCKY TRANSPORTATION CABINET AET REFERENCE DRAWINGS Downstream Mainline AET Toll Zone Gantry Elevation Single Direction - Front View (5 Lane)		
SCALE: N.T.S. Rev 1.1 4/12/2013	KENTUCKY TRANSPORTATION CABINET	SHEET NO. A-8

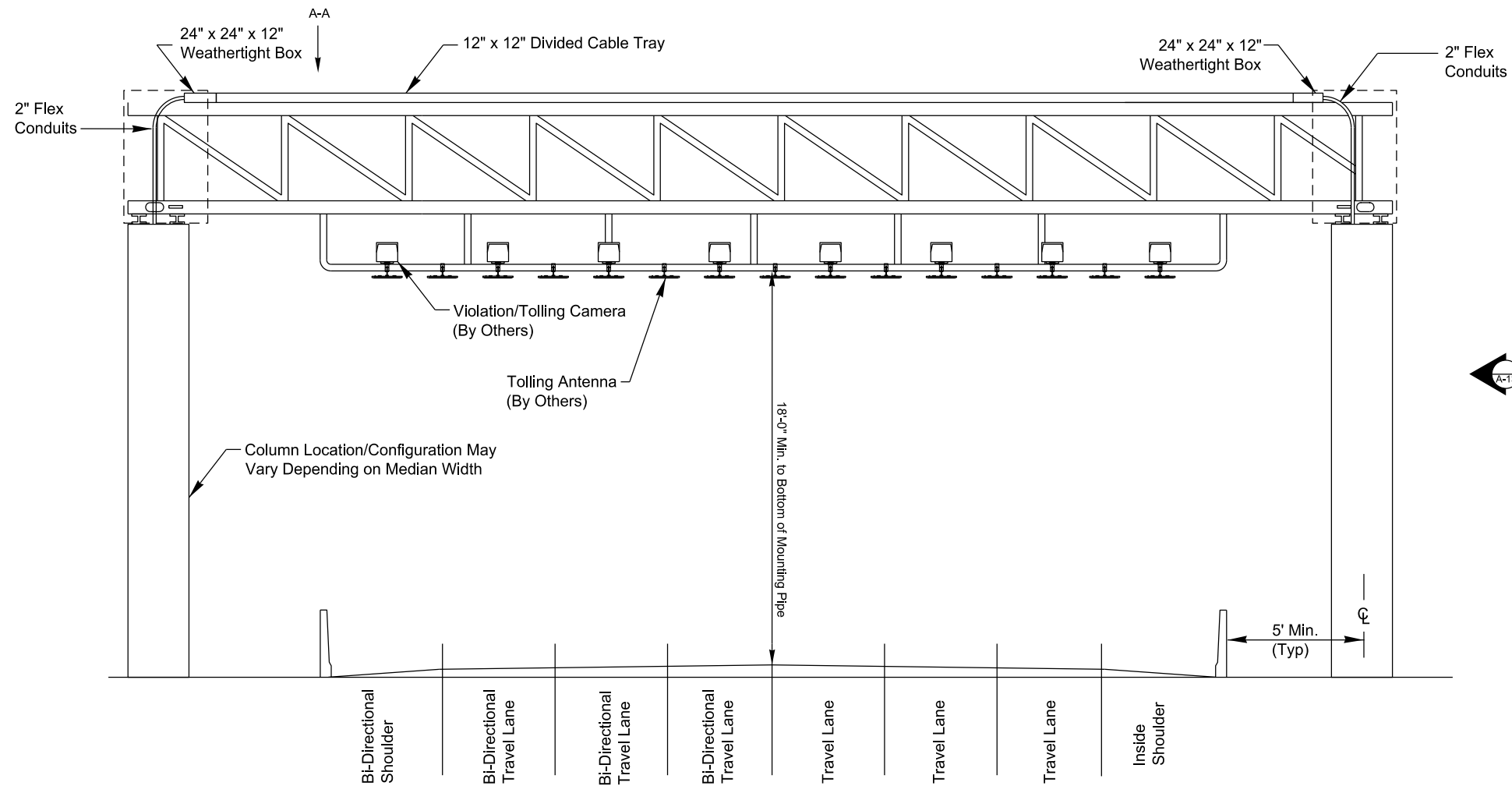

Upstream (First) Mainline Gantry Front Elevation , Bi-Directional
Not to Scale

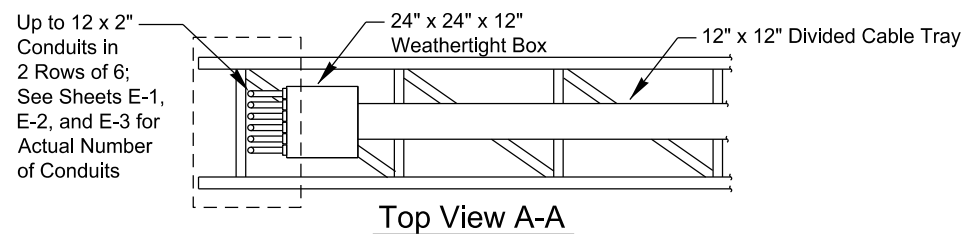

Notes:

1. Location of vertical supports to be coordinated by Toll System Integrator with Design Build Team and Developer.
2. Mounting pipes are horizontal.
3. Consider service walkways on gantry to minimize closures for maintenance.

ATKINS		1616 EAST MILLBROOK ROAD, SUITE 310 RALEIGH, NORTH CAROLINA 27609 (919) 876-6888
KENTUCKY TRANSPORTATION CABINET AET REFERENCE DRAWINGS Upstream Mainline AET Toll Zone Gantry Elevation Bi-Directional - Front View (6 Lane)		
SCALE:	N.T.S.	<small>KENTUCKY TRANSPORTATION CABINET</small> SHEET NO. A-9
Ver 1.1	3/22/2013	
Ver 1.2	4/12/2013	

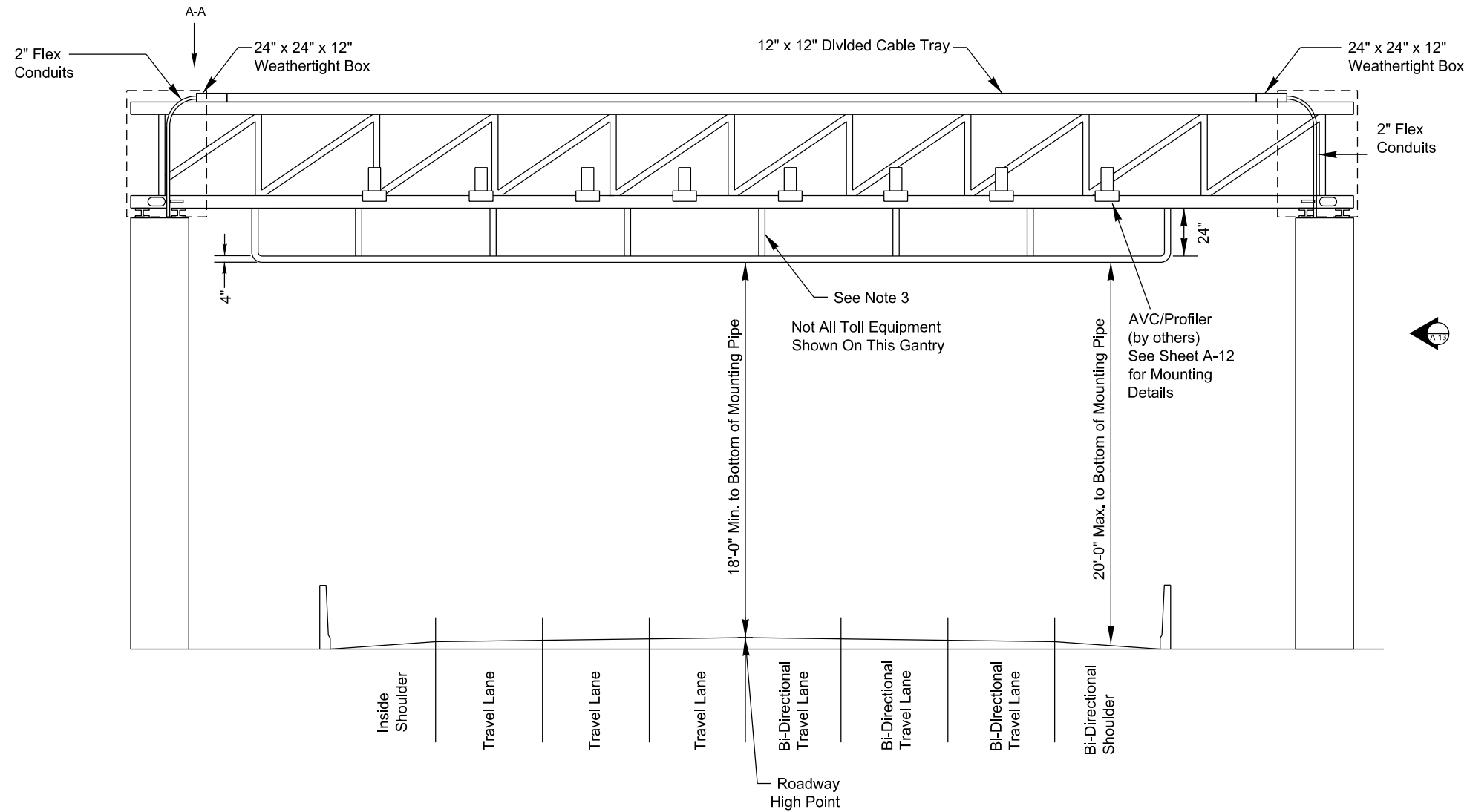

Upstream (First) Mainline Gantry Rear Elevation View, Bi-Directional
(Cameras and Antennas Omitted for Clarity)

Not to Scale

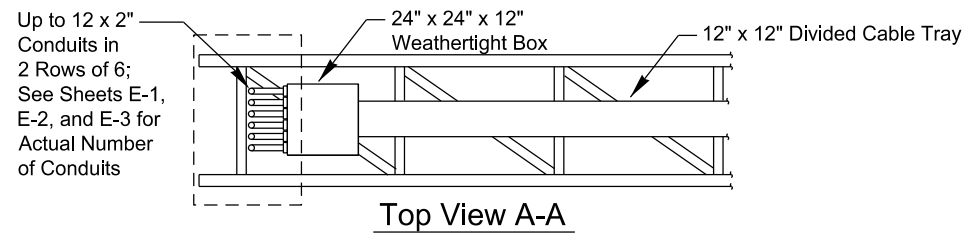

Notes:

1. Location of vertical supports to be coordinated by Toll System Integrator with Design Build Team and Developer.
2. Mounting pipes are horizontal.
3. Consider service walkways on gantry to minimize closures for maintenance.

ATKINS		1616 EAST MILLBROOK ROAD, SUITE 310 RALEIGH, NORTH CAROLINA 27609 (919) 876-6888
KENTUCKY TRANSPORTATION CABINET AET REFERENCE DRAWINGS Upstream Mainline AET Toll Zone Gantry Elevation Bi-Directional - Rear View (6 Lane)		
SCALE:	N.T.S.	KENTUCKY TRANSPORTATION CABINET
Ver 1.1	3/22/2013	
Ver 1.2	4/12/2013	
		SHEET NO. A-10

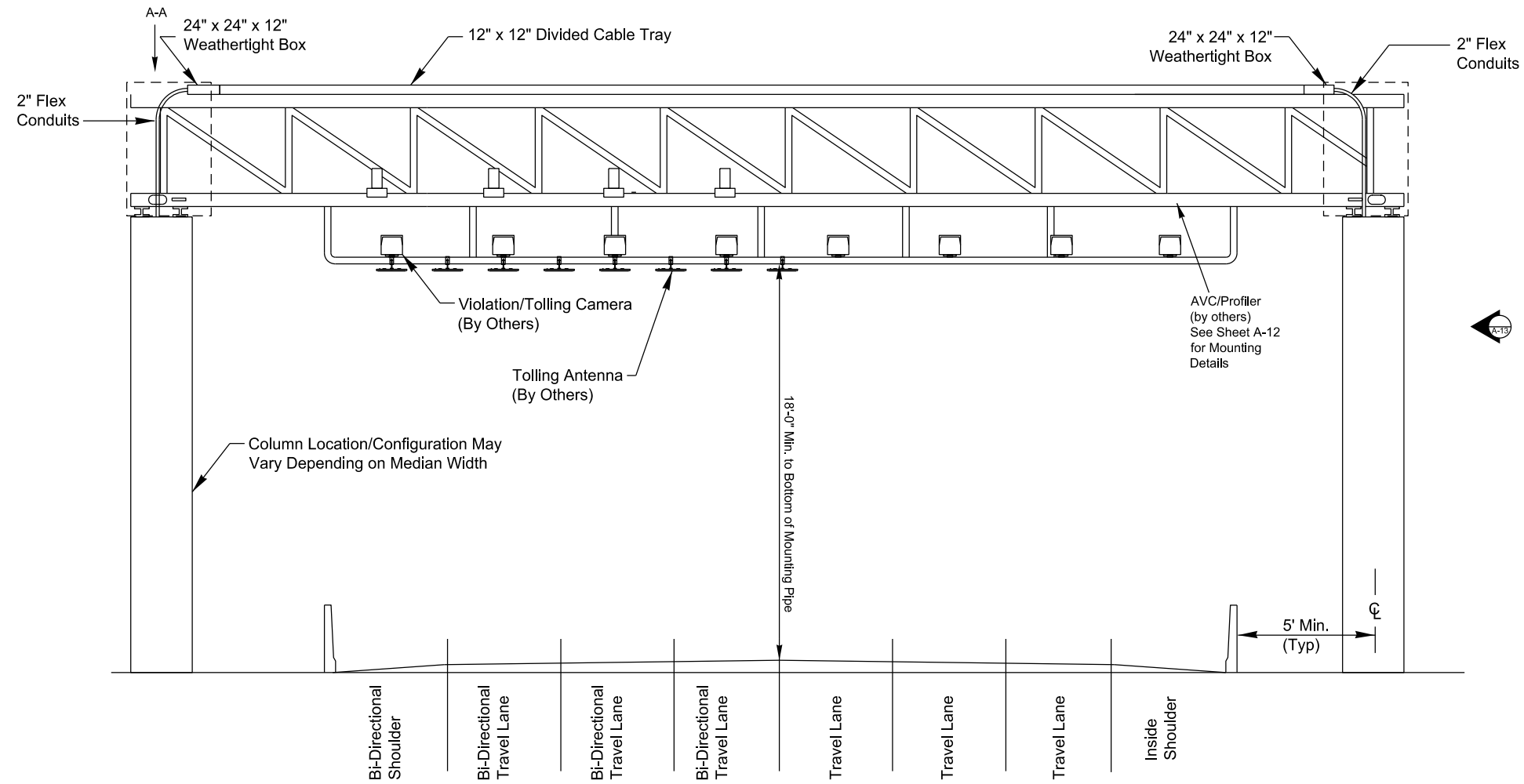

Downstream (Trailing) Mainline Gantry Front Elevation Bi-Directional
Not to Scale

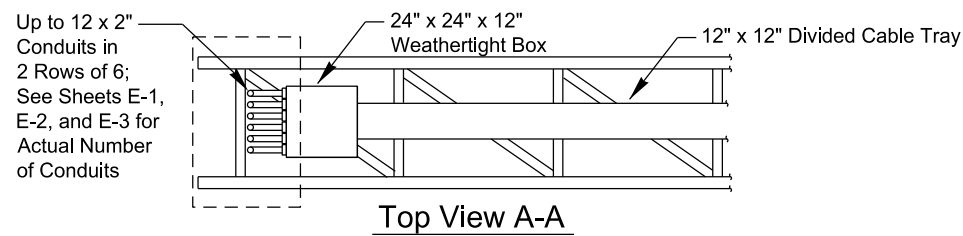

Notes:

1. Location of vertical supports to be coordinated by Toll System Integrator with Design Build Team and Developer.
2. Mounting pipes are horizontal.
3. Consider service walkways on gantry to minimize closures for maintenance

ATKINS		1616 EAST MILLBROOK ROAD, SUITE 310 RALEIGH, NORTH CAROLINA 27609 (919) 876-6888
KENTUCKY TRANSPORTATION CABINET AET REFERENCE DRAWINGS Downstream Mainline AET Toll Zone Gantry Elevation Bi-Directional - Front View (6 Lane)		
SCALE:	N.T.S.	KENTUCKY TRANSPORTATION CABINET
Ver 1.1	3/22/2013	
Ver 1.2	4/12/2013	
		SHEET NO. A-11

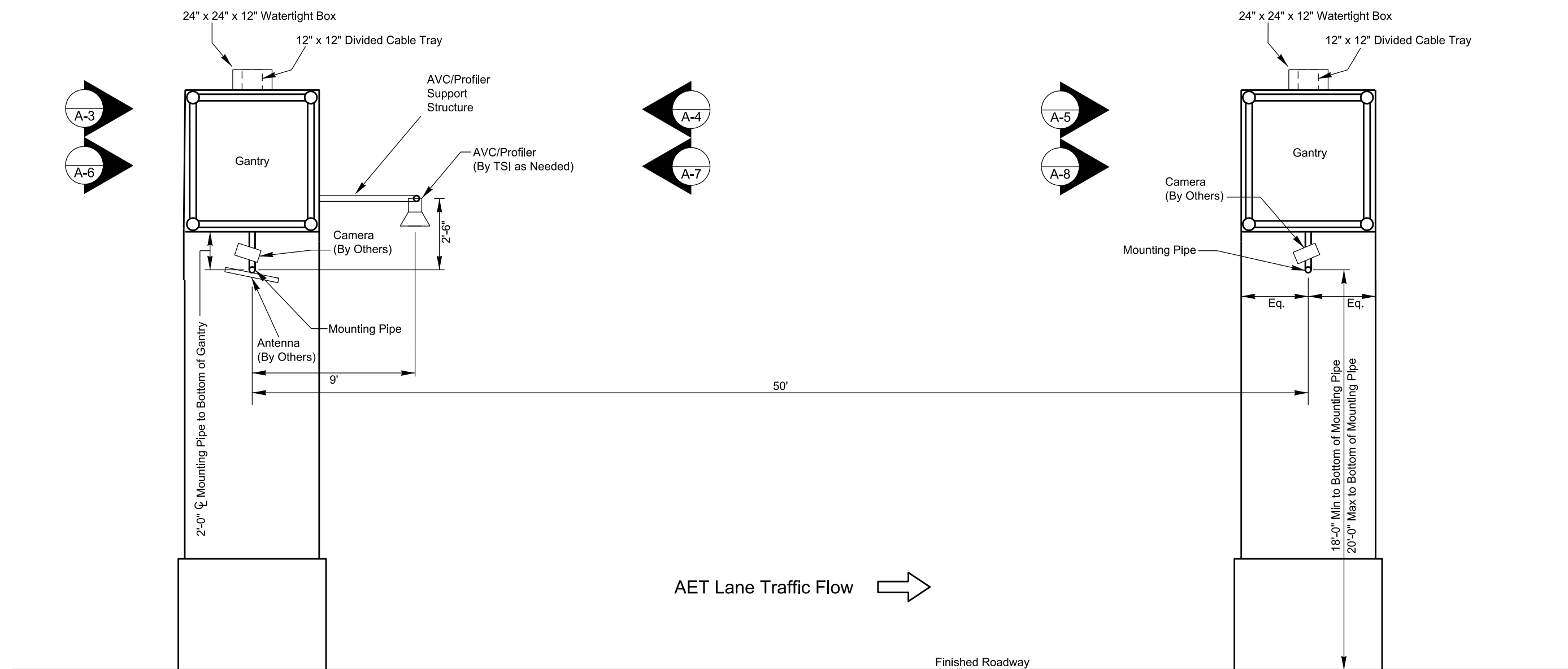

Gantry Side Elevation Single Direction
Not to Scale

Notes:

1. All mounting heights are to the centerline of the mounting pipe.
2. Heights are typical for both gantries..
3. Mounting pipes:
Camera/Antenna - 2" Rigid Galvanized Pipe.
AVC/Profiler - 3" Rigid Galvanized Pipe (if mounting pipe is used)
4. Divided cable tray shall be watertight (NEMA 3R) and grounded on both ends per NEC.
5. All conduit from the divided cable tray to the top of the columns shall be concealed behind cladding or earwalls.
6. Top of gantry aesthetic treatment shall be higher than top of cable tray and watertight box.

ATKINS		1616 EAST MILLBROOK ROAD, SUITE 310 RALEIGH, NORTH CAROLINA 27609 (919) 876-6888	
KENTUCKY TRANSPORTATION CABINET AET REFERENCE DRAWINGS Typical AET Toll Zone Gantry Side Elevation Single Direction			
SCALE:	N.T.S.	KENTUCKY TRANSPORTATION CABINET	SHEET NO. A-12
Ver 1.1	3/22/2013		
Ver 1.2	4/12/2013		

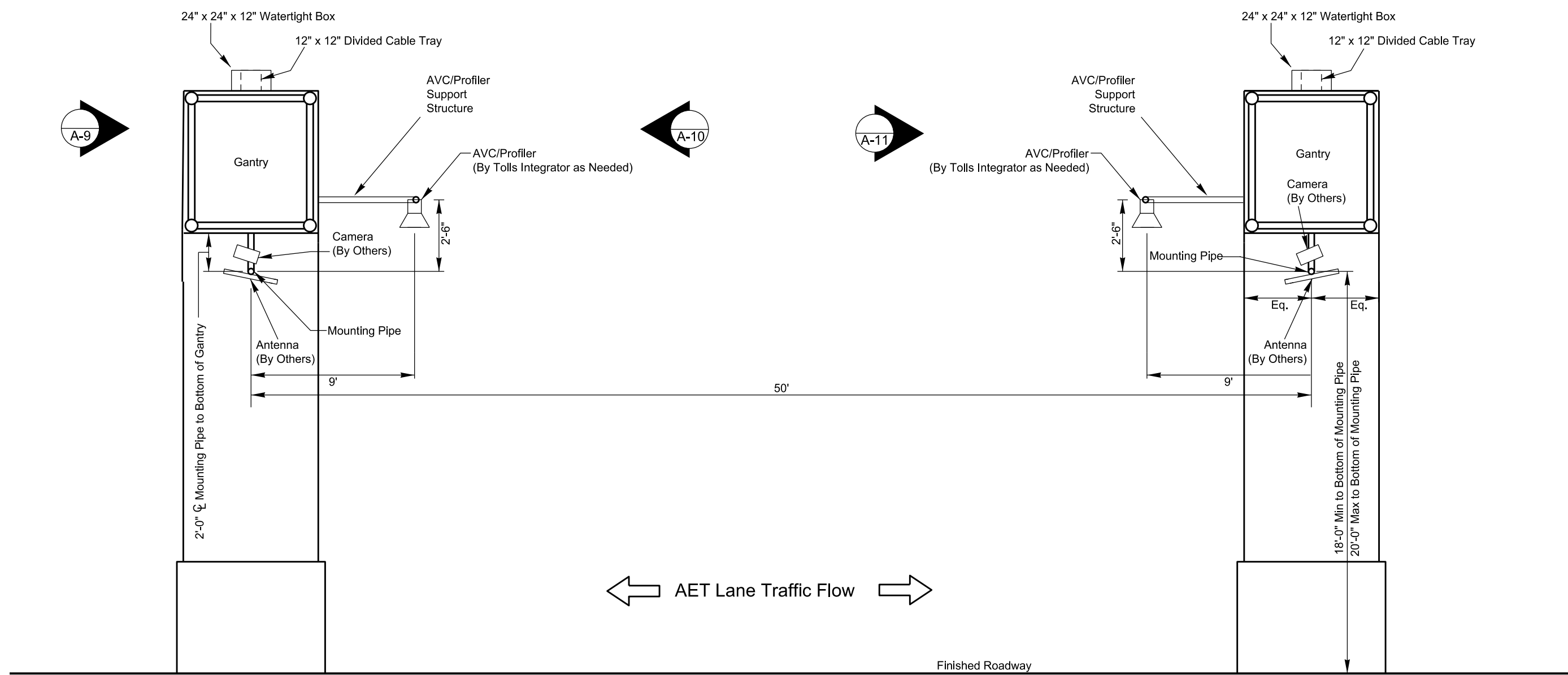

Gantry Side Elevation Single Direction
Not to Scale

Notes:

1. All mounting heights are to the centerline of the mounting pipe.
2. Heights are typical for both gantries.
3. Mounting pipes:
Camera/Antenna - 2" Rigid Galvanized Pipe.
AVC/Profiler - 3" Rigid Galvanized Pipe (if mounting pipe is used)
4. Divided cable tray shall be watertight (NEMA 3R) and grounded on both ends per NEC.
5. All conduit from the divided cable tray to the top of the columns shall be concealed behind cladding or earwalls.
6. Top of gantry aesthetic treatment shall be higher than top of cable tray and watertight box.

ATKINS		1616 EAST MILLBROOK ROAD, SUITE 310 RALEIGH, NORTH CAROLINA 27609 (919) 876-6888
KENTUCKY TRANSPORTATION CABINET AET REFERENCE DRAWINGS Typical AET Toll Zone Gantry Side Elevation Bi-Directional		
SCALE:	N.T.S.	KENTUCKY TRANSPORTATION CABINET
Ver 1.1	3/22/2013	
Ver 1.2	4/12/2013	
		A-13

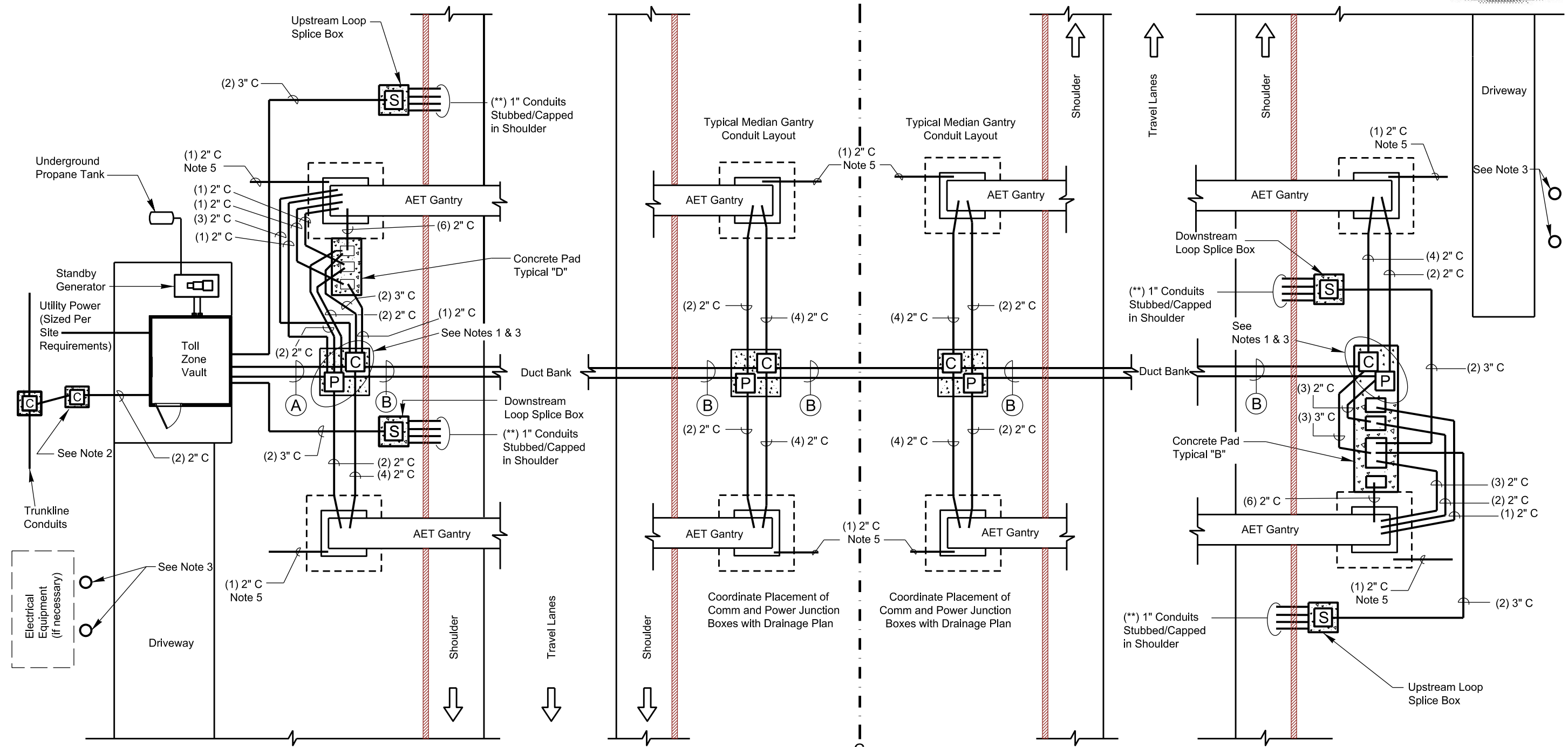

Legend

Notes:

1. Size junction boxes to fit conduit needs.
2. For all conduit runs entering Toll Zone Vault, place conduit boxes as needed to ensure last box before entering Toll Zone Vault is below level of sidewalk concrete slab.
3. Protect electrical equipment installed adjacent to driveway with concrete bollards.
4. Provide concrete aprons for all junction boxes.
5. Provide 2" conduit for Lightning Protection System grounding.

C - Communications Junction Box (36" x 24" x 24" Min)
P - Power Junction Box (30" x 17" x 24" Min)
S - Loop Splice Box (36" x 17" x 30" Min)
 - Box with 18" concrete apron, 1" above grade
 2" C - Designates 2" Conduit
 3" C - Designates 3" Conduit
 4" C - Designates 4" Conduit
 (#) - Designates Quantity
 - Cast-in-Place Concrete Barrier Wall (or Guard Rail)
 - Structure Foundation

Median Width Varies

(A) Conduit from Last Box to Vault
 Communications: (7) - 2" Conduits, (2) - 4" Conduits
 Power: (4) - 2" Conduits, (2) - 4" Conduits

(B) Duct Bank Detail
 Power, Communication & FON (As Needed)

 Roadway Crossing Duct Bank
 6-2" Conduit, 3-4" Conduit Encased in Concrete Unless Under Existing Roadway

** For upstream location, number of conduits typically = 2 x number of tolled lanes
 For downstream location, number of conduits typically = number of tolled lanes (shoulders greater than 4' wide count as "tolled lanes")

ATKINS 1616 EAST MILLBROOK ROAD, SUITE 310
 RALEIGH, NORTH CAROLINA 27609
 (919) 876-6888

KENTUCKY TRANSPORTATION CABINET
 AET REFERENCE DRAWINGS

Typical Mainline AET Toll Zone Conduit Detail

SCALE: N.T.S.	KENTUCKY TRANSPORTATION CABINET	SHEET NO.
Ver 1.1 3/22/2013		E-1
Ver 1.2 4/12/2013		

Legend

- C** - Communications Junction Box (36" x 24" x 24" Min)
- P** - Power Junction Box (30" x 17" x 24" Min)
- S** - Loop Splice Box (36" x 17" x 30" Min)
- Box with 18" concrete apron, 1" above grade
- 2" C - Designates 2" Conduit
- 3" C - Designates 3" Conduit
- 4" C - Designates 4" Conduit
- (#) - Designates Quantity
- Cast-in-Place Concrete Barrier Wall (or Guard Rail)
- Structure Foundation

(A) Conduit from Last Box to Vault

- Communications: (7) - 2" Conduits, (2) - 4" Conduits
- Power: (4) - 2" Conduits, (2) - 4" Conduits

(B) Duct Bank Detail

- Power, Communication & FON (As Needed)
- Power Comm
- Roadway Crossing Duct Bank: 6-2" Conduit, 3-4" Conduit Encased in Concrete Unless Under Existing Roadway

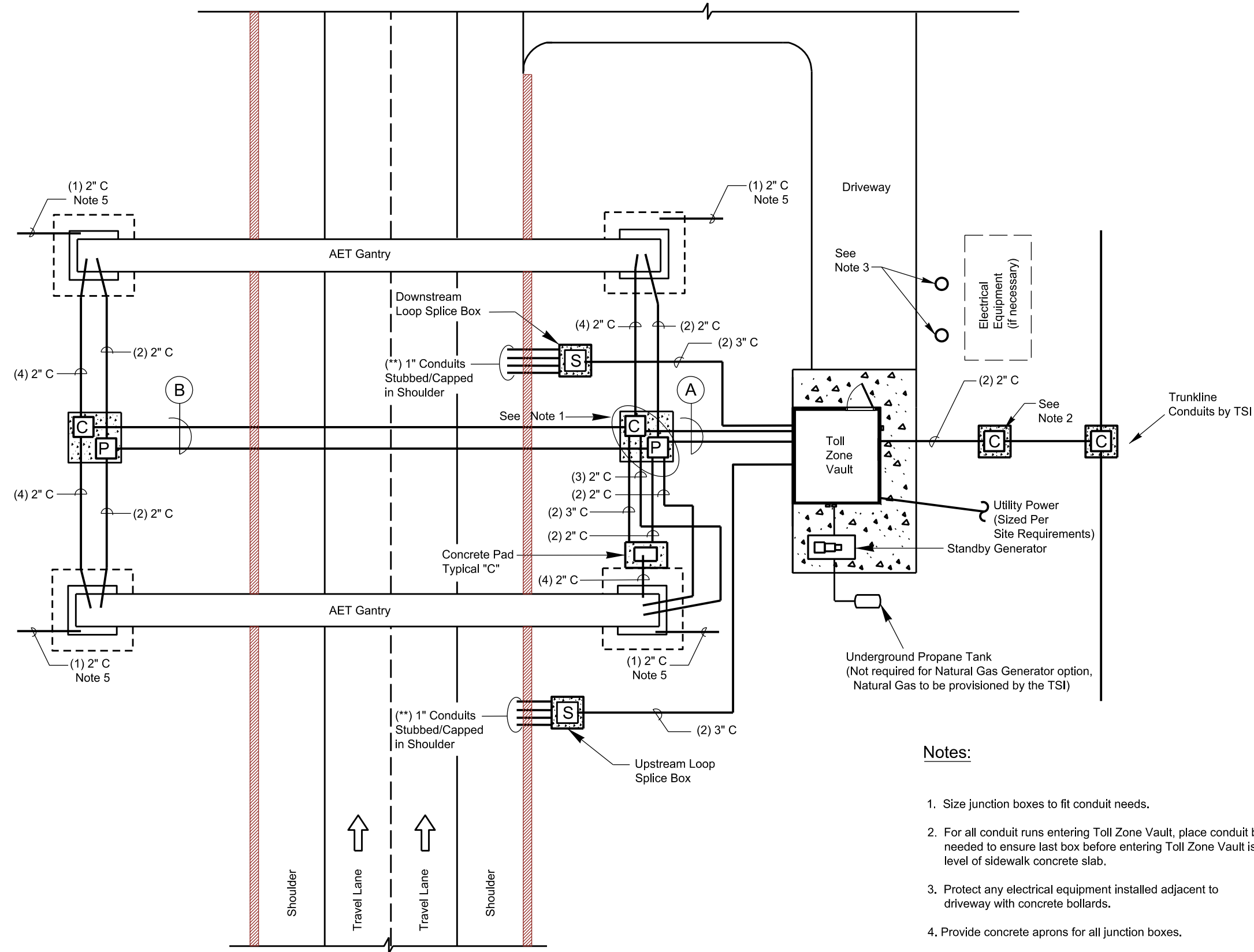

Notes:

1. Size junction boxes to fit conduit needs.
2. For all conduit runs entering Toll Zone Vault, place conduit boxes as needed to ensure last box before entering Toll Zone Vault is below level of sidewalk concrete slab.
3. Protect any electrical equipment installed adjacent to driveway with concrete bollards.
4. Provide concrete aprons for all junction boxes.
5. Provide 2" conduit for Lightning Protection System grounding.

** For upstream location, number of conduits typically = 2 x number of tolled lanes
 For downstream location, number of conduits typically = number of tolled lanes
 (shoulders greater than 4' wide count as "tolled lanes")

ATKINS		1616 EAST MILLBROOK ROAD, SUITE 310 RALEIGH, NORTH CAROLINA 27609 (919) 876-6888
KENTUCKY TRANSPORTATION CABINET AET REFERENCE DRAWINGS		
Typical Ramp AET Toll Zone Conduit Detail		
SCALE: N.T.S.	KENTUCKY TRANSPORTATION CABINET	SHEET NO.
Ver 1.1 3/22/2013		E-2
Ver 1.2 4/12/2013		

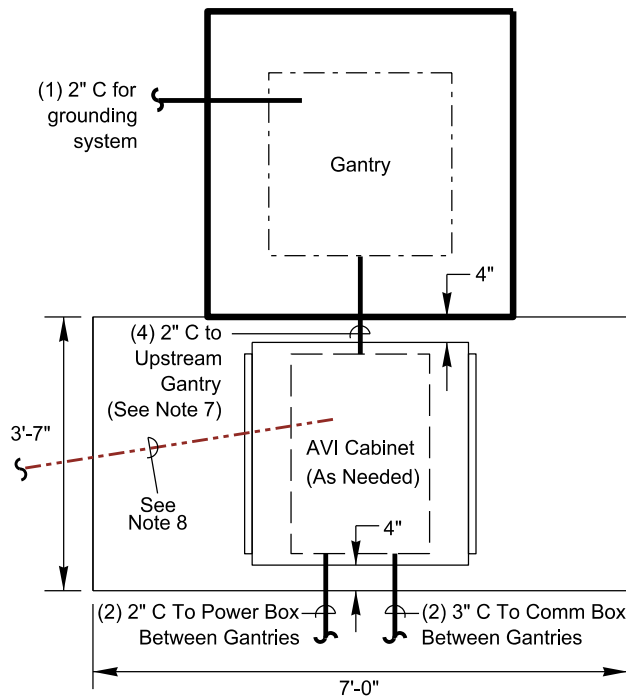

Pad Typical "A"
AVI Cabinet - As Needed
 N.T.S.

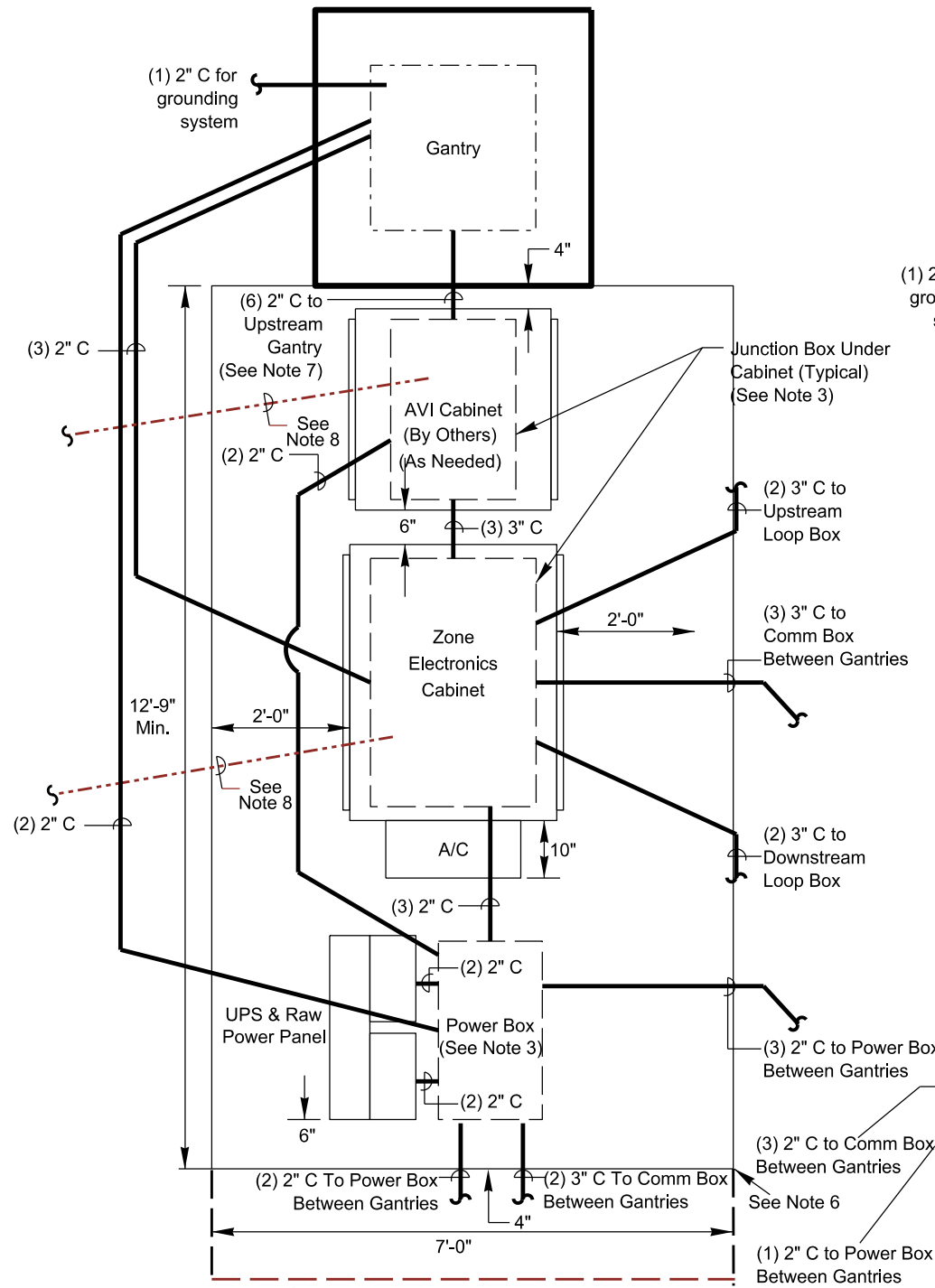

Pad Typical "B"
Zone Electronics and AVI Cabinets w/ Power Panel
 N.T.S.

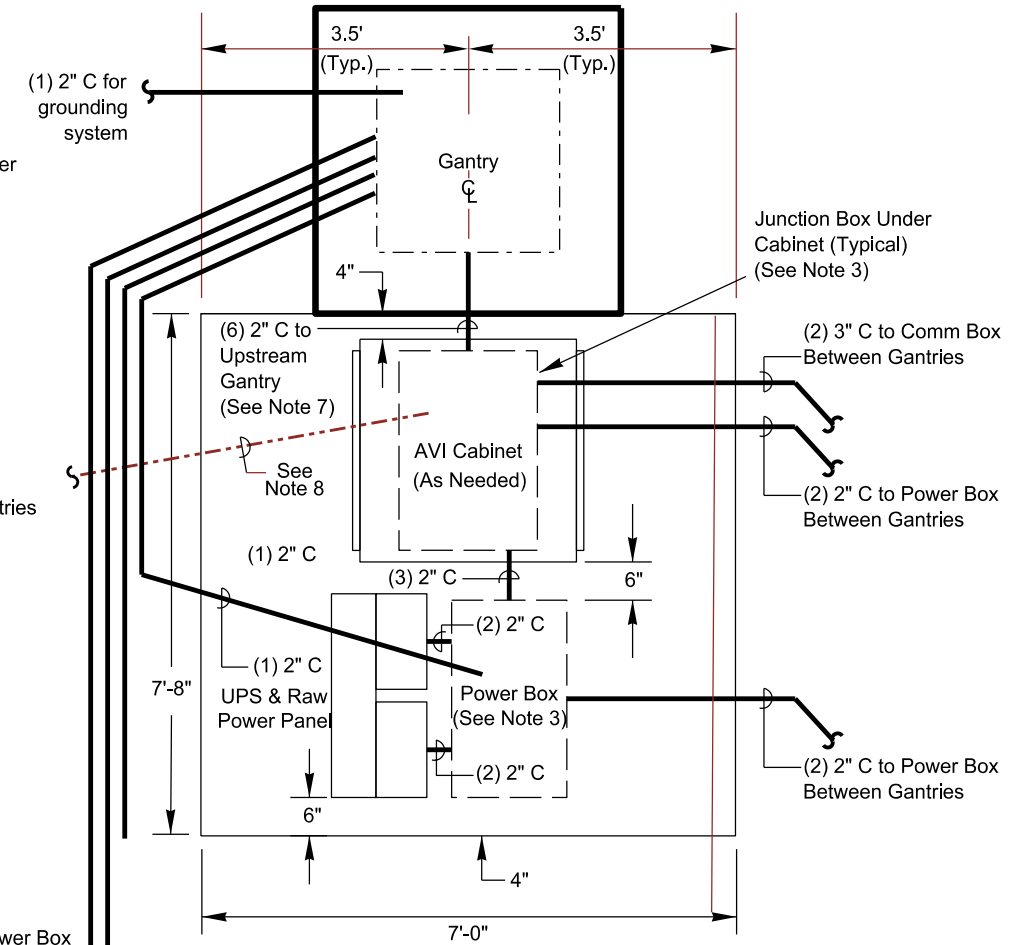

Pad Typical "C"
AVI Cabinet w/Power Panel
 N.T.S.

Notes:

1. Provide detailed conduit stub-up and interconnect diagrams. Coordinate conduit layout with Design Build Contractor and Developer.
2. At toll zones use rigid metallic conduit for exposed installations.
3. Size junction boxes as needed to fit conduit needs and cabinet sizes.
4. Coordinate pad conduit entry points with Design Build Contractor and Developer for proper location of stub-ups.
5. All cabinet sizes/dimensions are best information available and are subject to change by the TSI.
6. Refer to Sheet E-1 for extension of concrete pad.
7. Sweep conduit into side of junction box. Coordinate conduit location with Design Build Contractor and Developer.
8. Provide box drain for all boxes below equipment cabinets.
9. Pad shall be 8" thick (4" above and below finished grade).
10. Provide 3/4" chamfered edge on equipment pads.

Typical Cabinet Sizes

AVI Cabinet - 35"W x 34"D x 67"H
 Zone Cabinet - 48"W x 36"D x 72"H
 UPS & Raw Power Panel - 32"W x 16"D

ATKINS 1616 EAST MILLBROOK ROAD, SUITE 310
 RALEIGH, NORTH CAROLINA 27609
 (919) 876-6888

KENTUCKY TRANSPORTATION CABINET
 AET REFERENCE DRAWINGS

AET Toll Zone Cabinets with Concrete Pads

SCALE: N.T.S.	KENTUCKY TRANSPORTATION CABINET	SHEET NO. E-3
Ver 1.1 3/22/2013		
Ver 1.2 4/12/2013		



Legend

Symbol	Description	Remarks
	Industrial Fluorescent Fixture	Lithonia EJ-332-MVOLT
	Sharp Cut-Off Fluorescent Walpack Suitable for Wet Location	Lithonia TWFI-2/42TRT-120-CW20-LPI
	Combination Exit/Emergency Light	Lithonia LHQMS-W3R-120-H
	Outdoor Motion Sensor for Fixture Control	Watt Stopper EW-200-120-G
	20 AMP, Specification Grade Switch, Mount 42" A.F.F.	Hubbell 122I-I with PJ1 Cover
	Ultrasonic Motion Sensor Switch, Mount 42" A.F.F.	Watt Stopper UW-100-1
	Specification Grade 20 AMP, 120 Volt Duplex Receptacle Mount 18" A.F.F. Unless Otherwise Noted	Hubbell 5362-1 with PJ8 Cover Plate
	Specification Grade Weather Resistant/Ground Fault Interrupting Duplex Receptacle with In-Use Weather Proof Cover, Mount 18" A.F.F.	Hubbell GFTR20-** with WP26M Cover Plate
	New Concealed Wiring	Per NEC
	Unswitched Lighting Conductor	Per NEC
	Home Run to Panel Board; Numbers of Arrow Indicate Circuits	Per NEC
	Heavy Duty, Fusible Disconnect	Square D Heavy Duty
	Junction Box Sizing Per NEC	
	120/240V 1Ø, 3W Panel Board	Square D NQ
	Utility Meter Base	See Power Riser
	Vault Ground Bar	
	Above Finished Floor - Note All Mounting Dimensions Given are to the Bottom of the Outlet Box	
	Ground Rod Per NEC, Copper; Copper/Aluminum, See Scope of Work for Details	

Note: Locations of All Equipment May Vary

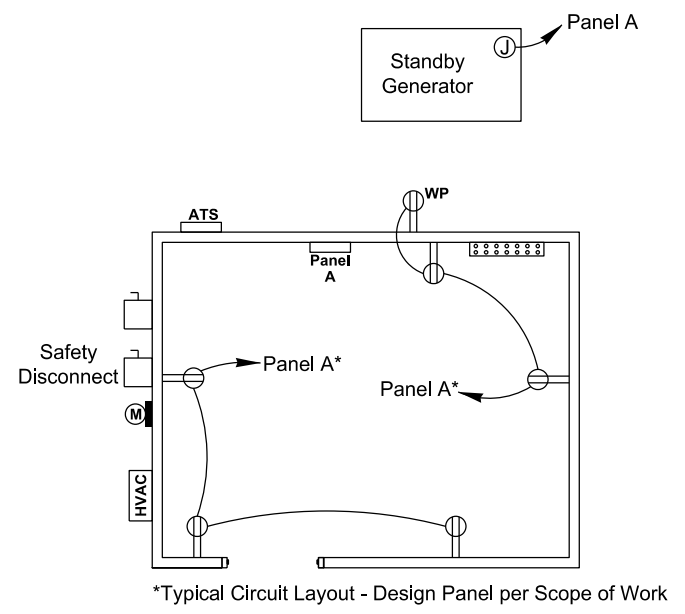

Power Plan
Not to Scale

Note: Lights and Motion Sensors may be Field Adjusted as Necessary to Provide Proper Illumination

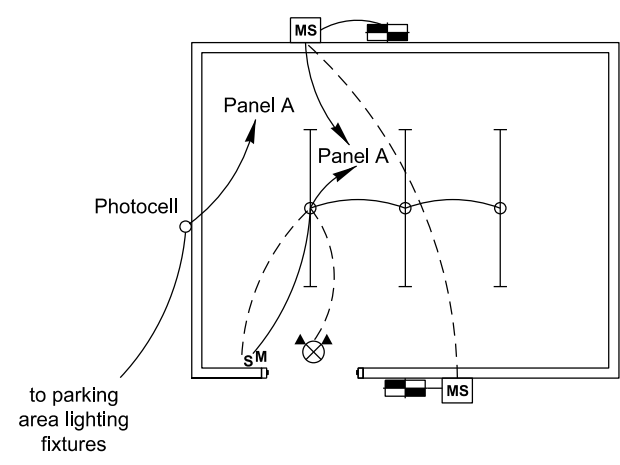

Lighting Plan
Not to Scale

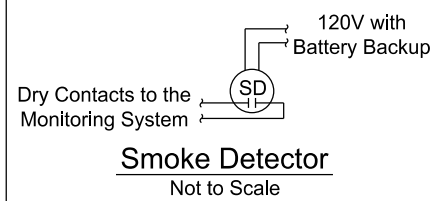
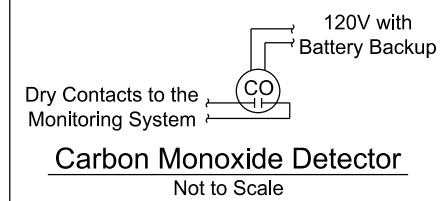

Key Notes:

- ① Utility Service Disconnect: Sized per Scope of Work, 2 Pole, NEMA 3R. Fuse at Rated AMPS
- ② Generator Service Disconnect: Sized per Scope of Work, 2 Pole, NEMA 3R Non Fused
- ③ New Automatic Transfer Switch: Sized per Scope of Work, Rated, 2 Pole, Neutral Conductor is not switched
- ④ KVA sized per Scope of Work 120/240 Volt, Single Phase, 3 Wire Standby Generator with the following features:
 - Provide exhaust silencer and sound attenuated weather proof enclosure
 - Provide 120 volt battery charger and 120 volt jacket heater
 - Generator shall be propane (LP) gas fired. Contractor to provide fuel tank with 120 hour capacity at full load. Provide all piping, valves, and regulators
 - Provide appropriately sized circuit breakers

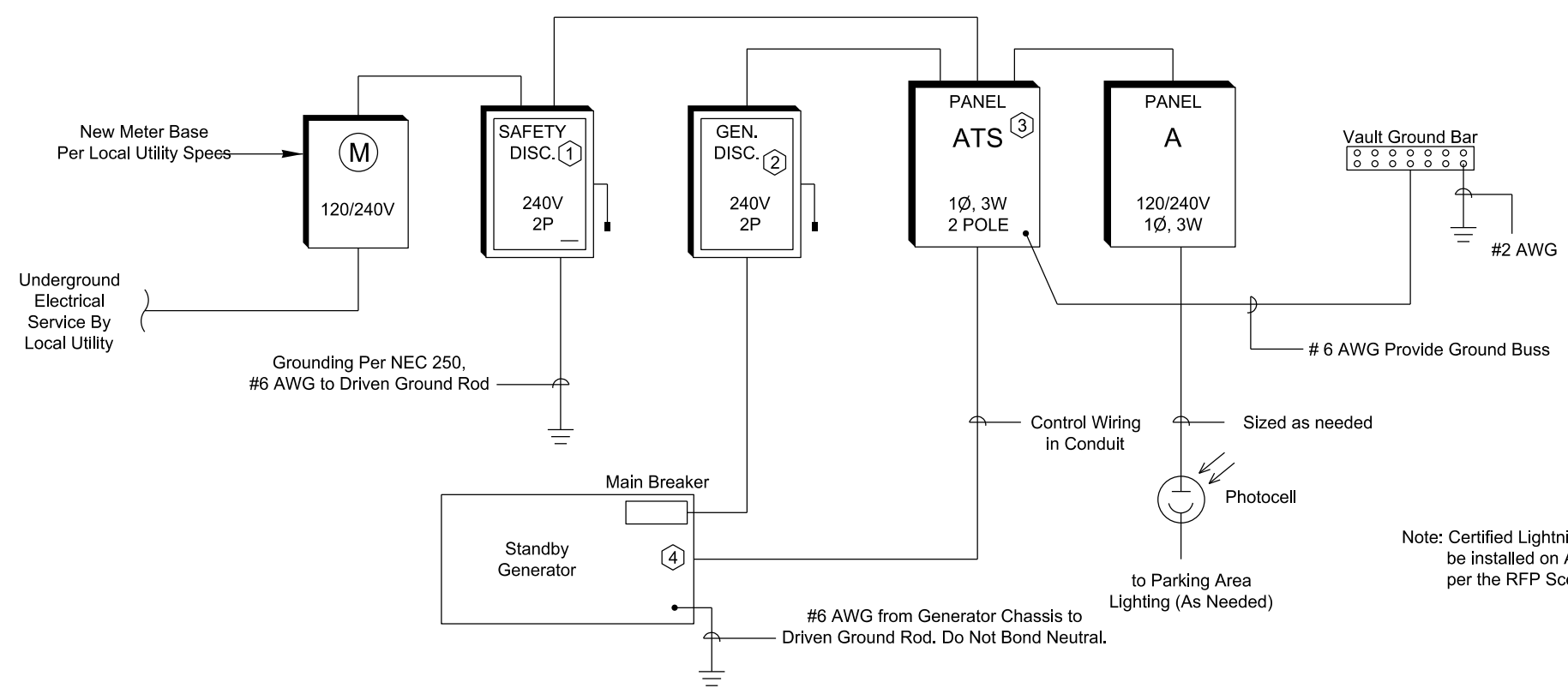

Note: Certified Lightning Protection System shall be installed on AET Toll Zone Vaults and gantries per the RFP Scope of Work

1616 EAST MILLBROOK ROAD, SUITE 310 RALEIGH, NORTH CAROLINA 27609 (919) 876-6888		
KENTUCKY TRANSPORTATION CABINET AET REFERENCE DRAWINGS Toll Zone Vault Electrical Plan		
SCALE: N.T.S.	KENTUCKY TRANSPORTATION CABINET	SHEET NO.
Ver 1.1 3/22/2013		E-4
Ver 1.2 4/12/2013		

